

## TECHNICAL INFORMATION GUIDE

### Xpress Coating Resin Systems

- **General Overview**
- **Technical Data Sheets**
- **Resin Usage Consumption**
- **Picote Brush Coating™ Certified Installer Training**
- **ASTM Testing**
- **Chemical Resistance**
- **SDS Sheets**



## TABLE OF CONTENTS

TOPIC	PAGE
GENERAL INFORMATION AND PRODUCT DESCRIPTION	3
TECHNICAL DATA SHEET	4
RESIN USAGE CONSUMPTION	7
PICOTE BRUSH COATING™ CERTIFIED INSTALLER TRAINING	8
ASTM TESTING EXPLAINED	9
ASTM LAB TESTING RESULTS	11
CHEMICAL RESISTANCE TESTING	14
SDS (SAFETY DATA SHEETS) - US	15
SDS (SAFETY DATA SHEETS) - EUROPE	24

To watch practical demonstration videos, take a course, or to download an electronic copy of these Instructions, please visit [www.picoteinstitute.com](http://www.picoteinstitute.com). Please note that videos and courses are not intended as a replacement or alternative to this operating and safety manual, but only as an additional learning tool.

## GENERAL INFORMATION / PRODUCT OVERVIEW

### PRODUCT DESCRIPTION:

This product has been created to renovate drains, sewers, water pipes, electrical conduits, heat and a/c ducts and more in concrete, PVC, fiberglass, clay, copper, cast iron, ductile iron, and steel pipes by brush casting a coating. The specially formulated coating resin forms a corrosion resistant or semi-structural repair inside the original pipe (depending on # of coats applied) that is a tested, safe and environmentally friendly product. The new pipe is corrosion resistant, anti-static, wear-resistant and non-corrosive. Thanks to a high breaking stretch, it also withstands shocks and bending.

### USES/BASIC METHODOLOGY:

- Extend the life span of the original pipe: The resin can be used to prolong the life of an existing pipe. Clean the pipe well. Apply 2 or more (1mm/coat) layers of the Xpress resin.
- The new slick inner surface will increase the flow inside the pipe minimizing the risk of blockages.
- Create a new semi-structural pipe: Apply multiple coats of the resin (use design calculator based on pipe diameter found in the manual or later in this document) to form a seamless new pipe with a 2-4mm wall thickness depending on the pipe diameter. Estimated 30-50 year design life when using Semi-Structural Design Specifications based on pipe diameter.

### BENEFITS FOR CONTRACTORS:

Extend the service life of a pipe, stop corrosion, create a new pipe, "patch" on top of CIPP liners and fortify connections\*. Apply to small areas or all drains in multi-story buildings. The Picote Coating™ System is affordable, practical and easily fits in tight places.

### BENEFITS FOR PROPERTY OWNERS:

Customers can stay at home or keep business open during drain renovation. A greener alternative eliminating the need to destroy existing walls, gardens or sidewalks, the no-dig solution reduces waste produced at job sites. Interruptions to traffic are also minimized. All materials used are non-toxic.

### HOW LONG WILL THE PIPE BE OUT OF SERVICE?:

Dry to touch in 3 hours with ambient cure.

Return to Service/Light Wear: 4 hours.

Final Hardness: 24 hours.

Full service can be restored 4 hours after last coat has been applied (24hrs for potable)

### TYPES OF PIPE:

Suitable for concrete, PVC, fiberglass, clay, copper, cast iron, ductile iron, and steel pipes. Preparation of the coating surface is dependent on the material of the pipe. Please see corresponding Picote Operation & Safety Manual.

### OPERATIONAL SETUP:

The Picote Brush Coating™ System and Xpress Resin is powered by the Picote Millers. Picote Millers can also be used for pipe preparation, drain cleaning and reinstatements on lateral connections. The system is practical and easy to keep clean.

*\*Ensure that materials are compatible and the surface is properly prepared.*

## TECHNICAL DATA SHEET

<b>GENERAL DESCRIPTION</b>	Xpress Resin 100% Solids Epoxy Dual component epoxy used to rehabilitate concrete, PVC, fiberglass, clay, copper, cast iron, ductile iron, and steel pipes. Creating a monolithic corrosion barrier or semi-structural repair of decayed and damaged pipes. Designed exclusively for the Picote Xpress Brush Coating™ System.
<b>NUMBER OF COMPONENTS</b>	2
<b>MIX RATIO</b>	1:1 mix ratio by volume in pre-packaged cartridges.
<b>PACKAGE SIZES</b>	Picote Epoxy Base - White (Part A) = Bucket (2.94 gallons/11.13 litres), 30.86 lbs Picote Epoxy Catalyst - Black (Part B) = Bucket (2.94 gallons/11.13 litres), 24.15 lbs
<b>PIPE DIAMETER RANGE</b>	1¼-12" (DN32-300) pipes.
<b>WORKING METHOD</b>	Coating applied with brush.
<b>COLOR USAGE</b>	Single Color (Grey)
<b>APPLICATION EQUIPMENT</b>	Picote Brush Coating™ System using Xpress Coating Pumps and Picote Millers.
<b>LEVELING</b>	Product is self-leveling.
<b>GAS EMISSIONS</b>	No harmful VOCs released during mixing or after hardening (VOC free).
<b>DRY CONTENT/SOLIDS</b>	100% solids (no solvents).
<b>FLASH POINT</b>	392°F (200°C).
<b>GLOSS</b>	Semi-gloss.
<b>THINNER</b>	Not used.
<b>SHRINKAGE</b>	100% Solids, does not shrink.
<b>HUMIDITY</b>	Hydrophobic, repels water.
<b>UV RESISTANCE</b>	Direct sunlight can alter color of coating.
<b>STATIC/CONDUCTIVITY</b>	Electrical insulating material, does not conduct electricity and is anti-static.
<b>SURFACE PREPARATION</b>	All surfaces to be coated must be dry and clean, free from oil, grease, debris and other contaminants. <b>Concrete:</b> must be jetted and cleaned removing any loose concrete. <b>Steel/Ductile Iron:</b> Near-White SSPC-SP10/NACE 2. Acceptable methods: sand blast, chain flail, or Picote Smart Cutter™ and Side Grinding Panels <b>Stainless Steel:</b> Nace No. 1/SSPC SP-5 White Metal Blast cleaning is needed and is beyond the capability of Picote cleaning tools. White metal blast cleaning is to be used to clean unpainted or painted steel surfaces prior to applying high-performance protective coating or lining systems. SSPC-SP 5/NACE No. 1 removes all visible oil, grease, dust, dirt, mill scale, rust, coating, oxides, corrosion products, and any other foreign matter on the surface.
<b>POT LIFE</b>	Mixed resin about 25 min @70°F (21°C).
<b>RATE OF COVERAGE</b>	See Picote Resin Calculator ( <a href="http://www.picoteinstitute.com">www.picoteinstitute.com</a> ) Average expected application per coat: .9-1mm (35.4-39.37 mils) Minimum expected application per coat: .8mm (mils (31.49 mils) Maximum expected application per coat: 1.2mm (47.2 mils)

## TECHNICAL DATA SHEET

### NUMBER OF COATS

Number of coats required is dependent on pipe diameter and rehabilitation goal  
Estimated 30-50 year design life when using Semi-Structural Design Specifications.  
Resistance to High Pressure Water Jetting:

- Minimum 4 coats need to be applied.
- Maximum Jetting Pressure: 2600 PSI (180 Bar).

Corrosion Resistance:

- After cleaning metal pipes, corrosion will come back quicker without coating.

Pipe Diameter	# of Coats for Corrosion Resistance	# of Coats for Semi Structural
1¼" (DN32)	1	1
1½" (DN40)	1	1
2" (DN50)	2	2
3" (DN70)	2	2
4" (DN100)	2	3 to 4
6" (DN150)	2 to 3	4 to 5
8" (DN200)	3 to 4	5 to 6
9" (DN225)	4 to 5	6 to 7
10" (DN250)	4 to 5	7 to 8
12" (DN300)	5 to 6	8 to 9

### HARDENING/CURE TIME

Recoat: 1 hours @77°F (25°C) using Picote Heater.

Restore flow: 4 hours (24 hours for potable water projects) @70°F (21°C).

Final Cure: 24 hours @70°F (21°C).

### RECOAT

Can be recoated within 12 hours without additional pipe preparation.

After 12 hours must be abraded with Picote Smart Cutter™ Side Grinding Panels.

### TEMPERATURES

Installation: 50-140°F (10-60°C).

Storage: Room Temperature 60-95°F (15.5-29°C).

Finished product: up to 180°F (82°C) in most commercial hot water applications.

### MECHANICAL TESTING

#### ASTM Testing:

Tensile Strength	D638	3,727 PSI
Tensile Elongation	D638	5.4%
Flexural Modulus	D790	134,211 PSI
Flexural Strength	D790	3,490 PSI
Adhesive Strength	D4541	Currently in Testing
Adhesion Strength Metal:		Currently in Testing
Adhesion Strength Concrete:		Currently in Testing

## TECHNICAL DATA SHEET

<b>SHELF-LIFE</b>	Unopened: 24 months from date of manufacture when stored according to recommended conditions. Opened: up to 6 weeks.
<b>STORAGE TEMPERATURE</b>	60-85°F (15.5-29°C).
<b>CLEAN UP</b>	Clean brushes using acetone. <b>REFER TO SAFETY DATA SHEET FOR SAFETY AND HEALTH INFORMATION.</b>
<b>INDUSTRIAL SAFETY</b>	Ready-measured product must not be in contact with skin (it adheres).
<b>SAFETY DATA SHEET (SDS)</b>	Available via QR code on resin packaging as well as online at <a href="http://www.picoteinstitute.com">www.picoteinstitute.com</a> in Picote Xpress Resin Technical Document.
<b>SHIPPING</b>	The two part resin is packaged in sealed buckets. Suggested storage at room temperature and in accordance with the guidelines in Technical Data Sheet.
<b>TECHNICAL ENQUIRIES</b>	Ryan Boldan, Global Learning Solutions Director 1 (864) 940-0088 <a href="mailto:ryan@picotesolutions.com">ryan@picotesolutions.com</a>  Richard Swan, Director of Client Technical Services 44 (0) 782 722 3237 <a href="mailto:richard@picotesolutions.com">richard@picotesolutions.com</a>

## RESIN USAGE CONSUMPTION

### RESIN CALCULATOR:

The Picote Xpress Resin Calculator is an Excel spreadsheet that can be downloaded from the Picote Institute online learning platform at [picoteinstitute.com](http://picoteinstitute.com). It calculates project resin usage based on pipe diameter, number of coats, and the length of the repair.

### XPRESS COATING PUMP % INDICATOR and COATING SCALE

The Picote Xpress Pump has a % scale chart located on the clear front door that visually correlates to the cylinder position to indicate the % of a full stroke that the cylinders have covered. This information can be used along with Coating Scale Charts (also part of the downloadable Xpress Resin Calculator) to show the maximum distance, by pipe diameter that the remaining resin in the Xpress Pump cylinders will cover.

		<b>Xpress Coating Scale (USA)</b>										
Scale is the maximum distance one full stroke of the Xpress Pump will cover.												
Scale	Pipe Diameter (Inches)											
%	1 1/4"	1 1/2"	2"	3"	4"	5"	6"	8"	9"	10"	12"	
0%	88.6 ft	65.6 ft	52.5 ft	32.8 ft	26.2 ft	23.0 ft	19.7 ft	13.1 ft	11.5 ft	9.8 ft	8.5 ft	
5%	84.2 ft	62.3 ft	49.9 ft	31.2 ft	24.9 ft	21.8 ft	18.7 ft	12.5 ft	10.9 ft	9.4 ft	8.1 ft	
10%	79.7 ft	59.1 ft	47.2 ft	29.5 ft	23.6 ft	20.7 ft	17.7 ft	11.8 ft	10.3 ft	8.9 ft	7.7 ft	
15%	75.3 ft	55.8 ft	44.6 ft	27.9 ft	22.3 ft	19.5 ft	16.7 ft	11.2 ft	9.8 ft	8.4 ft	7.3 ft	
20%	70.9 ft	52.5 ft	42.0 ft	26.2 ft	21.0 ft	18.4 ft	15.7 ft	10.5 ft	9.2 ft	7.9 ft	6.8 ft	
25%	66.4 ft	49.2 ft	39.4 ft	24.6 ft	19.7 ft	17.2 ft	14.8 ft	9.8 ft	8.6 ft	7.4 ft	6.4 ft	
30%	62.0 ft	45.9 ft	36.7 ft	23.0 ft	18.4 ft	16.1 ft	13.8 ft	9.2 ft	8.0 ft	6.9 ft	6.0 ft	
35%	57.6 ft	42.7 ft	34.1 ft	21.3 ft	17.1 ft	14.9 ft	12.8 ft	8.5 ft	7.5 ft	6.4 ft	5.5 ft	
40%	53.1 ft	39.4 ft	31.5 ft	19.7 ft	15.7 ft	13.8 ft	11.8 ft	7.9 ft	6.9 ft	5.9 ft	5.1 ft	
45%	48.7 ft	36.1 ft	28.9 ft	18.0 ft	14.4 ft	12.6 ft	10.8 ft	7.2 ft	6.3 ft	5.4 ft	4.7 ft	
50%	44.3 ft	32.8 ft	26.2 ft	16.4 ft	13.1 ft	11.5 ft	9.8 ft	6.6 ft	5.7 ft	4.9 ft	4.3 ft	
55%	39.9 ft	29.5 ft	23.6 ft	14.8 ft	11.8 ft	10.3 ft	8.9 ft	5.9 ft	5.2 ft	4.4 ft	3.8 ft	
60%	35.4 ft	26.2 ft	21.0 ft	13.1 ft	10.5 ft	9.2 ft	7.9 ft	5.2 ft	4.6 ft	3.9 ft	3.4 ft	
65%	31.0 ft	23.0 ft	18.4 ft	11.5 ft	9.2 ft	8.0 ft	6.9 ft	4.6 ft	4.0 ft	3.4 ft	3.0 ft	
70%	26.6 ft	19.7 ft	15.7 ft	9.8 ft	7.9 ft	6.9 ft	5.9 ft	3.9 ft	3.4 ft	3.0 ft	2.6 ft	
75%	22.1 ft	16.4 ft	13.1 ft	8.2 ft	6.6 ft	5.7 ft	4.9 ft	3.3 ft	2.9 ft	2.5 ft	2.1 ft	
80%	17.7 ft	13.1 ft	10.5 ft	6.6 ft	5.2 ft	4.6 ft	3.9 ft	2.6 ft	2.3 ft	2.0 ft	1.7 ft	
85%	13.3 ft	9.8 ft	7.9 ft	4.9 ft	3.9 ft	3.4 ft	3.0 ft	2.0 ft	1.7 ft	1.5 ft	1.3 ft	
90%	8.9 ft	6.6 ft	5.2 ft	3.3 ft	2.6 ft	2.3 ft	2.0 ft	1.3 ft	1.1 ft	1.0 ft	0.9 ft	
95%	4.4 ft	3.3 ft	2.6 ft	1.6 ft	1.3 ft	1.1 ft	1.0 ft	0.7 ft	0.6 ft	0.5 ft	0.4 ft	
100%	0 ft	0 ft	0 ft	0 ft	0 ft	0 ft	0 ft	0 ft	0 ft	0 ft	0 ft	

		<b>Xpress Coating Scale (Metric)</b>										
Scale is the maximum distance one full stroke of the Xpress Pump will cover.												
Scale	Pipe Diameter (MM)											
%	32	40	50	70	100	125	150	200	225	250	300	
0%	27.0 m	20.0 m	16.0 m	10.0 m	8.0 m	7.0 m	6.0 m	4.0 m	3.5 m	3.0 m	2.6 m	
5%	25.7 m	19.0 m	15.2 m	9.5 m	7.6 m	6.7 m	5.7 m	3.8 m	3.3 m	2.9 m	2.5 m	
10%	24.3 m	18.0 m	14.4 m	9.0 m	7.2 m	6.3 m	5.4 m	3.6 m	3.2 m	2.7 m	2.3 m	
15%	23.0 m	17.0 m	13.6 m	8.5 m	6.8 m	6.0 m	5.1 m	3.4 m	3.0 m	2.6 m	2.2 m	
20%	21.6 m	16.0 m	12.8 m	8.0 m	6.4 m	5.6 m	4.8 m	3.2 m	2.8 m	2.4 m	2.1 m	
25%	20.3 m	15.0 m	12.0 m	7.5 m	6.0 m	5.3 m	4.5 m	3.0 m	2.6 m	2.3 m	2.0 m	
30%	18.9 m	14.0 m	11.2 m	7.0 m	5.6 m	4.9 m	4.2 m	2.8 m	2.5 m	2.1 m	1.8 m	
35%	17.6 m	13.0 m	10.4 m	6.5 m	5.2 m	4.6 m	3.9 m	2.6 m	2.3 m	2.0 m	1.7 m	
40%	16.2 m	12.0 m	9.6 m	6.0 m	4.8 m	4.2 m	3.6 m	2.4 m	2.1 m	1.8 m	1.6 m	
45%	14.9 m	11.0 m	8.8 m	5.5 m	4.4 m	3.9 m	3.3 m	2.2 m	1.9 m	1.7 m	1.4 m	
50%	13.5 m	10.0 m	8.0 m	5.0 m	4.0 m	3.5 m	3.0 m	2.0 m	1.8 m	1.5 m	1.3 m	
55%	12.2 m	9.0 m	7.2 m	4.5 m	3.6 m	3.2 m	2.7 m	1.8 m	1.6 m	1.4 m	1.2 m	
60%	10.8 m	8.0 m	6.4 m	4.0 m	3.2 m	2.8 m	2.4 m	1.6 m	1.4 m	1.2 m	1.0 m	
65%	9.4 m	7.0 m	5.6 m	3.5 m	2.8 m	2.5 m	2.1 m	1.4 m	1.2 m	1.1 m	0.9 m	
70%	8.1 m	6.0 m	4.8 m	3.0 m	2.4 m	2.1 m	1.8 m	1.2 m	1.1 m	0.9 m	0.8 m	
75%	6.7 m	5.0 m	4.0 m	2.5 m	2.0 m	1.8 m	1.5 m	1.0 m	0.9 m	0.8 m	0.7 m	
80%	5.4 m	4.0 m	3.2 m	2.0 m	1.6 m	1.4 m	1.2 m	0.8 m	0.7 m	0.6 m	0.5 m	
85%	4.0 m	3.0 m	2.4 m	1.5 m	1.2 m	1.1 m	0.9 m	0.6 m	0.5 m	0.5 m	0.4 m	
90%	2.7 m	2.0 m	1.6 m	1.0 m	0.8 m	0.7 m	0.6 m	0.4 m	0.4 m	0.3 m	0.3 m	
95%	1.3 m	1.0 m	0.8 m	0.5 m	0.4 m	0.4 m	0.3 m	0.2 m	0.2 m	0.2 m	0.1 m	
100%	0 m	0 m	0 m	0 m	0 m	0 m	0 m	0 m	0 m	0 m	0 m	

## PICOTE BRUSH COATING™ CERTIFIED INSTALLER TRAINING

### TRAINING CENTRES:

- Phoenix, Arizona, USA
- Porvoo, Finland
- Sandhurst, England, UK



Picote Certified Installer Training for Picote Brush Coating™ is highly recommended to get the most out of your investment and provide the highest quality finished results.

For Picote Brush Coating™ Certified Installer Training you will receive a Picote ID Card for completion (UK only), which can be used for the tendering process and on site.

Certificates are awarded for all certification trainings.

Visit our website at [www.picotegroup.com](http://www.picotegroup.com) or contact us at [training@picotesolutions.com](mailto:training@picotesolutions.com) to find out about course offerings, pricing, and scheduling.

## 10 YEAR WARRANTY\*

When using the Picote Brush Coating™ System as an option for semi-structural pipe rehabilitation you are providing a solution that can last 30-50 years. When you successfully complete Picote Certified Installer Training you will be able to offer a 10 year warranty on the Picote Xpress Epoxy Resin when you meet the outlined criteria. This provides assurance for the end-user as well as an advantage when you tender for work.

\*Terms & conditions apply, ask for details.



## ASTM TESTING EXPLAINED

### TESTED PRODUCT: Picote Xpress Resin

### TESTS 1&2

A total of 4 tests were performed including:

1. Tensile Strength
2. Tensile Elongation
3. Flexural Modulus
4. Flexural Strength

#### TEST 1: ASTM D638-14 "Tensile Strength"

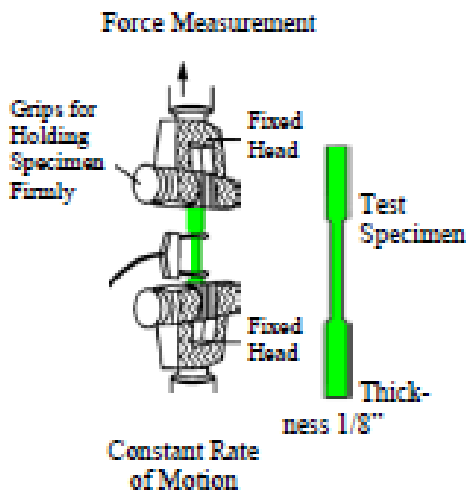

A piece of finished product, with a maximum thickness of .125-inches, is machined into a dog-bone shape. Each end of the test specimen is placed in opposite facing clamps which then attempt to pull it apart.

The PSI that it takes to break the specimen is calculated as "Tensile Strength at the Break". The "Tensile Elongation at the Break" is an additional measurement that shows how much the product stretches during this test. The "Tensile Modulus" is a measure taken to test rigidity. All of these measurements make up the "Tensile Strength" test. The D638-14 test would simulate separating pipe joints and the effect that would have on the product in question.

#### TEST 1 RESULTS: Picote Xpress Resin Tensile Test

Test Method:	ASTM D638-14
Test Conditions:	23±2°C, 50±10% R.H.
Conditioning:	40+ hours, 23±2°C, 50±10% R.H.
Preparation:	Machined from sample sent by client
Specimen:	Type I tensile bars (2-inch gage length)
Cross Head Speed:	0.2-inches per minute

Sample	Replicate	Width (inches)	Thickness (inches)	Tensile Strength at Break (psi)	Tensile Elongation at Break (%)
<b>Picote Xpress Resin</b>					
		0.501 avg	0.104 avg	3,727 PSI	5.4%
<b>Requirement</b>				n/a	n/a

## ASTM TESTING EXPLAINED

### TESTED PRODUCT: Picote Xpress Resin

### TESTS 3&4

A total of 4 tests were performed including:

1. Tensile Strength
2. Tensile Elongation
3. Flexural Modulus
4. Flexural Strength

#### TEST 3: D790-15e2 "Flexural Modulus"

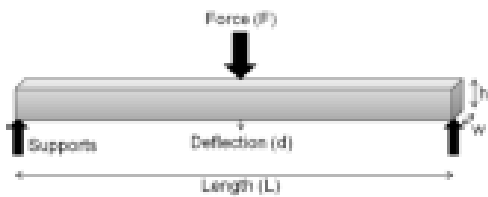

This test is used to measure the horizontal strength of the material. Supports are placed under the sample at each end, and then a piston drives down at the center. The force to drive down and the amount of deflection are measured to come up with the specimen's "Flexural Modulus".

This test would simulate areas in a coated pipe that are being subjected to uneven stress.

#### TEST 3 RESULTS: Picote Xpress Resin Flexural Test

Test Method:	ASTM D790-15e2, Procedure A
Test Conditions:	23±2°C, 50±10% R.H.
Conditioning:	40+ hours, 23±2°C, 50±10% R.H.
Preparation:	Machined from sample sent by client
Support Span:	3.641 inches
Cross Head Speed:	0.090 inches per minute

Sample	Replicate	Width (inches)	Depth	Flexural Strength at Break (PSI)	Flexural Modulus (KSI)
<b>Picote Xpress Resin</b>					
	5	0.525 average	.227 average	3,490	134,211
<b>Requirement</b>					

# PICOTE XPRESS RESIN SYSTEM

Version:  
January 16, 2024

## ASTM LAB TESTING RESULTS

HTS Pipe Consultants, Inc.  
420 Pickering Street, Houston, TX 77091  
www.htspipeconsultants.com

Phone 713-692-8373  
Fax 713-692-8502  
Toll Free 1-800-692-TEST



November 2, 2023

<b>HTS Report #:</b>	<b>23-P-0626-01</b>		
Mr. Matt Peterson Quadex 564 W. 9320 South Sandy, UT 84070	Customer Project Name:	XPress	
	Customer Project No.:		
	Date Sample Received:	10/30/23	
	Date Sample Tested:	11/02/23	

One (1) plate sample was delivered to HTS' laboratory for testing. The sample was tested in accordance with ASTM D638 Type II and ASTM D790 Method I Procedure A. A Support Span-to-Depth Ratio of 16 to 1 was used as specified in the test standard ASTM D790. Thickness measurements, tensile strength, flexural stress, and flexural modulus of elasticity tests were performed on the sample. Five (5) specimens were cut and tested from the sample. The results summarized and reported below are averages of the five (5) specimens. A test report for the sample is attached.

SAMPLE ID	TENSILE STRENGTH (psi) ASTM D 638	TENSILE ELONGATION (%) ASTM D 638	FLEXURAL STRENGTH (psi) ASTM D 790	FLEXURAL MODULUS (psi) ASTM D 790
Xpress	3727	5.4	3490	134,211

The following table contains the thickness measurements for each individual specimen tested.

MEASUREMENT OF THICKNESS FOR CURED IN PLACE PIPE LINER ASTM D 2122										
Sample ID	No. 1	No. 2	No. 3	No. 4	No. 5	No. 6	No. 7	No. 8	Combined Total Average/Specimen	
									in	mm
Xpress	.238	.235	.218	.223	.238	.208	.233	.220	0.227	5.8

Technician	E. Carrillo
Time	2 hrs.

Sincerely,

  
Rick Eastwood VP  
Vice President

This test report relates only to the items tested and shall not be reproduced except in full without approval of HTS, Inc.

23-P-0626-01-Q.Doc – Page 1 of 1

Serving the Pipe Rehabilitation Industry

# PICOTE XPRESS RESIN SYSTEM

Version:  
January 16, 2024

## ASTM LAB TESTING RESULTS

11/2/2023

TENSILE PROPERTIES OF PLASTIC  
ASTM D638  
TYPE II

INSTRON  
BLUEHILL V4.24 (34TM-30)

OPERATOR NAME	EFRAIN C.
TEMPERATURE	71 F
HUMIDITY	50 %
Rate 1	0.20 in/min
SAMPLE ID	XPRESS

	WIDTH [in]	THICKNESS [in]	GUAGE LENGTH [in]	GRIP DISTANCE [in]
1	0.284	0.207	2.0	5.3
2	0.232	0.208	2.0	5.3
3	0.272	0.209	2.0	5.3
4	0.272	0.204	2.0	5.3
5	0.271	0.216	2.0	5.3

	TENSILE STRENGHT @ MAX [psi]	ELONGATION @ MAX [%]
1	3275	4.3
2	3843	5.4
3	3995	5.6
4	3249	4.3
5	4273	7.3
Mean	3727	5.4
Std. dev	451.53	1.22
Minimum	3249	4.3
Maximum	4273	7.3

F23P-0626-T1\_is\_tens



## ASTM LAB TESTING RESULTS

Wednesday, November 01, 2023

FLEXURAL PROPERTIES OF PLASTICS  
ASTM D790  
3 POINT BEND

INSTRON CORPORATION  
BLUEHILL V. 2.26 (#4411)

OPERATOR NAME:  
DAVID P

TEMPERATURE (F) / HUMIDITY (%)  
71 / 50

RATE (in/min)  
.093

SAMPLE ID:

XPRESS

	WIDTH (in)	THICKNESS (in)	SUPPORT SPAN (in)
1	0.525	0.225	3.5
2	0.513	0.227	3.5
3	0.547	0.227	3.5
4	0.518	0.228	3.5
5	0.524	0.229	3.5

	STRAIN @ MAX (in/in)	MAXIMUM LOAD (lbf)	FLEXURAL STRENGTH (psi)	FLEXURAL MODULUS (psi)
1	0.0497	17.6	3475	137357
2	0.0499	17.8	3542	136848
3	0.0499	17.8	3311	128414
4	0.0498	18.9	3677	134598
5	0.0498	18.0	3442	133836
Mean	0.0498	18.0	3490	134211
Standard Deviation	0.0001	0.5	135	3562
Minimum	0.0497	17.6	3311	128414
Maximum	0.0499	18.9	3677	137357

F23P-0626-1.is\_flex



## CHEMICAL RESISTANCE



**Chemical Soak Tests for the Xpress Resin System are currently in process.**

**We will update this document as soon as the results are available.**

**For additional information or questions, please contact Picote Solutions.**

## SDS SHEET - XPRESS A, BASE WHITE - US



### SAFETY DATA SHEET

PICOTE BRUSH COATING™ EPOXY RESIN  
XPRESS A (COLOR: WHITE)

Revision date: 8-9-2023

#### SAFETY DATA SHEET

#### SECTION 1 . INDENTIFICATION

Product Name: PICOTE Approved 3/29/23 Express 1:1 Product Code: XPRESS A

Picote Solutions  
20810 SE 18th PL  
Sammamish,WA 98075

EMERGENCY CONTACT: INFOTRAC  
DOMESTIC & CANADA : 800-535-5053  
INTERNATIONAL: 352-323-3500

#### SECTION 2. HAZARD(S) IDENTIFICATION

##### GHS Ratings:

Skin corrosion/irritation	3	Reversible adverse effects in dermal tissue, Draize score: >= 1.5 < 2.3
Skin sensitization	1	Skin sensitizer
Carcinogenicity	2	Limited evidence of human or animal carcinogenicity

##### GHS Hazards

H316	Causes mild skin irritation
H317	May cause an allergic skin reaction
H351	Suspected of causing cancer

##### GHS Precautions

P201	Obtain special instructions before use
P202	Do not handle until all safety precautions have been read and understood
P261	Avoid breathing dust/fume/gas/mist/vapours/spray
P272	Contaminated work clothing should not be allowed out of the workplace
P280	Wear protective gloves/protective clothing/eye protection/face protection
P281	Use personal protective equipment as required
P321	Specific treatment (see ... on this label)
P363	Wash contaminated clothing before reuse
P302+P352	IF ON SKIN: Wash with soap and water
P308+P313	IF exposed or concerned: Get medical advice/attention
P332+P313	If skin irritation occurs: Get medical advice/attention
P333+P313	If skin irritation or a rash occurs: Get medical advice/attention
P405	Store locked up
P501	Dispose of contents/container to ...

Signal Word: Warning



#### SECTION 3. COMPOSITION/INFORMATION ON INGREDIENTS

Chemical Name	CAS number	Weight Concentration %
Epoxy Resin	25085-99-8	70.00% - 80.00%
Titanium Dioxide	13463-67-7	10.00% - 20.00%
Proprietary	68609-97-2	5.00% - 10.00%
Silica	67762-90-7	1.00% - 5.00%

## SDS SHEET - XPRESS A, BASE WHITE - US

### SECTION 4. FIRST AID MEASURES

If inhaled remove to fresh air. If breathing is difficult, give oxygen. Obtain medical advice if there are persistent symptoms

Rinse immediately with plenty of water for at least 15 minutes. Ensure adequate flushing of the eyes by separating the eyelids with fingers. Remove contacts if present and easy to do. Continue Rinsing. Get medical attention, if irritation or symptoms of overexposure persists.

Immediately wash skin with soap and plenty of water.

If swallowed, call a physician immediately. Only induce vomiting at the instruction of a physician. Never give anything by mouth to an unconscious person

### SECTION 5. FIRE FIGHTING MEASURES

Flash Point: 252 C (486 F)

LEL: N/A

UEL: N/A

Not applicable

Foam, Carbon dioxide (CO<sub>2</sub>) or dry chemical or water spray (water stream may be ineffective).

No information available

Not available

Firefighters, and others exposed, wear self-contained breathing apparatus.

### SECTION 6. ACCIDENTAL RELEASE MEASURES

Stop leak. Dike or contain spill. Pump into slavage tanks and/or absorb with suitable material. Use sparkless shovel to remove material. Evacuate area and keep unnecessary and unprotected personnel from entering the spill area.

Use appropriate containment and clean up immediately.

Stop leak, Dike and contain spill. Prevent spilled material from entering the ground, water and/or air by using appropriate containment methods.

### SECTION 7. HANDLING and STORAGE

Avoid breathing vapor. Avoid contact with eyes, skin and clothing. Keep away from heat and flame. Keep container closed. Use with adequate ventilation. Wash thoroughly after handling.

Avoid exposure to heat, light, and air for prolonged periods of time. Store in a cool, dry well ventilated area away from sources of heat and incompatible materials. Eliminate all ignition materials and incompatible materials.

Collect spill with non spark tools.

No information available.

### SECTION 8. EXPOSURE CONTROLS, PERSONAL PROTECTION

Chemical Name / CAS No.	OSHA Exposure Limits	ACGIH Exposure Limits	Other Exposure Limits
Epoxy Resin 25085-99-8	Not Established	Not Established	Not Established
Titanium Dioxide 13463-67-7	15 mg/m <sup>3</sup> TWA (total dust)	10 mg/m <sup>3</sup> TWA	Not Established
Proprietary 68609-97-2	Not Established	Not Established	Not Established
Silica 67762-90-7	Not Established	Not Established	Not Established

Use appropriate engineering control such as process enclosures, local exhaust ventilation, or other engineering controls to control airborne levels below recommended exposure limits. Good general ventilation should be sufficient to control airborne levels. Where



## SDS SHEET - XPRESS A, BASE WHITE - US

such systems are not effective wear suitable personal protective equipment, which preforms satisfactory and meets OSHA or other recognized standards. Consult with local procedures for selection, training, and maintenance of the personal protective equipment Always use adequate ventilation that comply with local regulations.

**Eye/face Protection:** Wear appropriate protective glasses or splash goggles as described by 29 CFR 1910.133, OSHA eye and face protection regulation, or the European standard EN 166

**Skin Protection:** Chemical-resistant gloves and chemical goggles, face-shield and synthetic apron or coveralls should be used to prevent contact with eyes, skin or clothing.

**Respiratory Protection:** A NIOSH air purifying respirator with an organic vapor cartridge or canister may be permissible under certain circumstances where airborne concentrations are expected to exceed exposure limits. Protection provided by air purifying respirators is limited. Use a positive pressure air supplied respirator if there is any potential for an uncontrolled release, exposure levels are not known or any other circumstance where air purifying respirator may not provide adequate protection.

### SECTION 9. PHYSICAL and CHEMICAL PROPERTIES

<b>Boiling Range</b> 2500 to 3000 °C <b>Lbs VOC/Gallon Less Water</b> 0.00 <b>% VOL by Volume</b> 0.00	<b>Specific Gravity (SG)</b> 1.258 <b>Lbs VOC/Gallon Less</b> 0.00 <b>Exempt</b>
--	--

### SECTION 10. STABILITY and REACTIVITY

Stable, Hazardous polymerization will not occur.

**STABLE**

Strong acids, caustics, oxidizers, Avoid uncontrolled exposure to Epoxy Resin, Amine.

No Data Found

None known, other than Sec. #2 and Sec #5

Hazardous polymerization will not occur.

### SECTION 11. TOXICOLOGICAL INFORMATION

#### Mixture Toxicity Component Toxicity

No Data Found

Respiratory System

#### Effects of Overexposure

CAS Number  
13463-67-7

Description  
Titanium Dioxide

% Weight  
10% - 20%

Carcinogen Rating  
Titanium Dioxide: NIOSH:  
potential occupational carcinogen  
IARC: Possible human carcinogen  
OSHA: listed

Avoid breathing vapors

Oral: N.D.A.  
Dermal: N.D.A.  
Inhalation: N.D.A.

## SDS SHEET - XPRESS A, BASE WHITE - US

### SECTION 12. ECOLOGICAL INFORMATION

No ecotoxicity data was found for the product

#### Component Ecotoxicity

### SECTION 13. DISPOSAL INFORMATION

Dispose of in accordance with applicable local/municipal, state/provincial and federal regulations.

### SECTION 14. TRANSPORT INFORMATION

UN3082 Environmentally Hazardous Substance, Liquid N.O.S. (Epoxy Resin)

Packaging Group III:

Hazardous Class 9

<u>Agency</u>	<u>Proper Shipping Name</u>	<u>UN Number</u>	<u>Packing Group</u>	<u>Hazard Class</u>
---------------	-----------------------------	------------------	----------------------	---------------------

### SECTION 15. REGULATORY INFORMATION

OSHA:29 CFR 1910.1200 Hazardous Chemical "Irritant", Sensitizer

<u>Country</u>	<u>Regulation</u>	<u>All Components Listed</u>
----------------	-------------------	------------------------------

### SECTION 16. ADDITIONAL INFORMATION

#### Hazardous Material Information System (HMIS)

HEALTH	2	<b>HMIS &amp; NFPA Hazard Rating Legend</b> * = Chronic Health Hazard 0 = INSIGNIFICANT 1 = SLIGHT 2 = MODERATE 3 = HIGH
FLAMMABILITY	1	
PHYSICAL HAZARD	0	
PERSONAL PROTECTION	C	

#### National Fire Protection Association (NFPA)

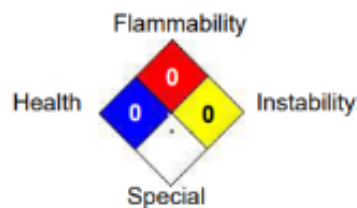

Date Revised: 8/8/2023

Date Prepared: 7/27/2023

Reviewer Revision

## SDS SHEET - XPRESS B, CATALYST BLACK - US



### SAFETY DATA SHEET

PICOTE BRUSH COATING™ EPOXY RESIN  
XPRESS B (COLOR: BLACK)

Revision date: 8-9-2023

#### SAFETY DATA SHEET

#### SECTION 1 . IDENTIFICATION

Product Name: ACTIVATOR Approved 3/29/23 Express 1:1 Product Code: XPRESS B

Picote Solutions  
20810 SE 18th PL  
Sammamish, WA 98075

EMERGENCY CONTACT: INFOTRAC  
DOMESTIC & CANADA : 800-535-5053  
INTERNATIONAL: 352-323-3500

#### SECTION 2. HAZARD(S) IDENTIFICATION

##### GHS Ratings:

Skin corrosion/irritation	1B	Destruction of dermal tissue: Exposure < 1 hour Observation < 14 days, visible necrosis in at least one animal
Serious eye damage/eye irritation	1	Serious eye damage: Irreversible damage 21 days after exposure, Draize score: Corneal opacity >= 3, Iritis > 1.5
Skin sensitization	1	Skin sensitizer
Carcinogenicity	2	Limited evidence of human or animal carcinogenicity
Reproductive toxicity	2	Human or animal evidence possibly with other information

##### GHS Hazards

H314	Causes severe skin burns and eye damage
H317	May cause an allergic skin reaction
H318	Causes serious eye damage
H351	Suspected of causing cancer
H361	Suspected of damaging fertility or the unborn child

##### GHS Precautions

P201	Obtain special instructions before use
P202	Do not handle until all safety precautions have been read and understood
P260	Do not breathe dust/fume/gas/mist/vapours/spray
P261	Avoid breathing dust/fume/gas/mist/vapours/spray
P264	Wash ... thoroughly after handling
P272	Contaminated work clothing should not be allowed out of the workplace
P280	Wear protective gloves/protective clothing/eye protection/face protection
P281	Use personal protective equipment as required
P310	Immediately call a POISON CENTER or doctor/physician
P321	Specific treatment (see ... on this label)
P363	Wash contaminated clothing before reuse
P301+P330+P331	IF SWALLOWED: Rinse mouth. Do NOT induce vomiting
P302+P352	IF ON SKIN: Wash with soap and water
P303+P361+P353	IF ON SKIN (or hair): Remove/Take off immediately all contaminated clothing. Rinse skin with water/shower
P304+P340	IF INHALED: Remove victim to fresh air and keep at rest in a position comfortable for breathing
P305+P351+P338	IF IN EYES: Rinse continuously with water for several minutes. Remove contact lenses if present and easy to do – continue rinsing
P308+P313	IF exposed or concerned: Get medical advice/attention
P333+P313	If skin irritation or a rash occurs: Get medical advice/attention
P405	Store locked up
P501	Dispose of contents/container to ...

## SDS SHEET - XPRESS B, CATALYST BLACK - US

Signal Word: Danger



### SECTION 3. COMPOSITION/INFORMATION ON INGREDIENTS

Chemical Name	CAS number	Weight Concentration %
Aminoethyl piperazine, 1-(2-, (AEP)	140-31-8	80.00% - 90.00%
nonyl phenol	84852-15-3	5.00% - 10.00%
Amine	217-168-8	5.00% - 10.00%
Inert	INERT	1.00% - 5.00%
Black Pigment	1333-86-4	0.10% - 1.00%

### SECTION 4. FIRST AID MEASURES

If inhaled remove to fresh air. If breathing is difficult, give oxygen. Obtain medical advice if there are persistent symptoms

Rinse immediately with plenty of water for at least 15 minutes. Ensure adequate flushing of the eyes by separating the eyelids with fingers. Remove contacts if present and easy to do. Continue Rinsing. Get medical attention, if irritation or symptoms of overexposure persists.

Immediately wash skin with soap and plenty of water.

If swallowed, call a physician immediately. Only induce vomiting at the instruction of a physician. Never give anything by mouth to an unconscious person

### SECTION 5. FIRE FIGHTING MEASURES

Flash Point: N/A

LEL: N/A

UEL: N/A

Not applicable

Foam, Carbon dioxide (CO<sub>2</sub>) or dry chemical or water spray (water stream may be ineffective).

No information available

Not available

Firefighters, and others exposed, wear self-contained breathing apparatus.

### SECTION 6. ACCIDENTAL RELEASE MEASURES

Stop leak. Dike or contain spill. Pump into slavage tanks and/or absorb with suitable material. Use sparkless shovel to remove material. Evacuate area and keep unnecessary and unprotected personnel from entering the spill area.

Use appropriate containment and clean up immediately.

Corrosive. Avoid personal contact and breathing vapor or mist. Stop leak, Dike and contain spill. Prevent spilled material from entering the ground, water and/or air by using appropriate containment methods.

### SECTION 7. HANDLING and STORAGE

Avoid breathing vapor. Avoid contact with eyes, skin and clothing. Keep away from heat and flame. Keep container closed. Use with adequate ventilation. Wash thoroughly after handling.

Avoid exposure to heat, light, and air for prolonged periods of time. Store in a cool, dry well ventilated area away from sources of heat and incompatible materials. Eliminate all ignition materials and incompatible materials.

Collect spill with non spark tools.

No information available.

### SECTION 8. EXPOSURE CONTROLS, PERSONAL PROTECTION

# PICOTE XPRESS RESIN SYSTEM

Version:  
January 16, 2024

## SDS SHEET - XPRESS B, CATALYST BLACK - US

Chemical Name / CAS No.	OSHA Exposure Limits	ACGIH Exposure Limits	Other Exposure Limits
Aminoethyl) piperazine, 1-(2-, (AEP) 140-31-8	Not Established	Not Established	Not Established
nonyl phenol 84852-15-3	Not Established	Not Established	Not Established
Amine 217-168-8	Not Established	Not Established	Not Established
Inert INERT	Not Established	Not Established	Not Established
Black Pigment 1333-86-4	3.5 mg/m <sup>3</sup> TWA	3 mg/m <sup>3</sup> TWA (inhalable fraction)	NIOSH: 3.5 mg/m <sup>3</sup> TWA; 0.1 mg/m <sup>3</sup> TWA (Carbon black in presence of Polycyclic aromatic hydrocarbons, as PAH)

Use appropriate engineering control such as process enclosures, local exhaust ventilation, or other engineering controls to control airborne levels below recommended exposure limits. Good general ventilation should be sufficient to control airborne levels. Where such systems are not effective wear suitable personal protective equipment, which performs satisfactory and meets OSHA or other recognized standards. Consult with local procedures for selection, training, and maintenance of the personal protective equipment. Always use adequate ventilation that comply with local regulations.

Eye/Face Protection: Wear appropriate protective glasses or splash goggles as described by 29 CFR 1910.133, OSHA eye and face protection regulation, or the European standard EN 166

Skin Protection: Chemical-resistant gloves and chemical goggles, face-shield and synthetic apron or coveralls should be used to prevent contact with eyes, skin or clothing.

Respiratory Protection: A NIOSH air purifying respirator with an organic vapor cartridge or canister may be permissible under certain circumstances where airborne concentrations are expected to exceed exposure limits. Protection provided by air purifying respirators is limited. Use a positive pressure air supplied respirator if there is any potential for an uncontrolled release, exposure levels are not known or any other circumstance where air purifying respirator may not provide adequate protection.

### SECTION 9. PHYSICAL and CHEMICAL PROPERTIES

<p><b>Specific Gravity (SG)</b> 0.988</p> <p><b>Lbs VOC/Gallon Less Exempt</b> 0.00</p>	<p><b>Lbs VOC/Gallon Less Water</b> 0.00</p> <p><b>% VOL by Volume</b> 0.00</p>
---	---

### SECTION 10. STABILITY and REACTIVITY

Stable, Hazardous polymerization will not occur. Will react with Epoxy Resins especially at elevated temperatures

**STABLE**

Epoxy Resins under uncontrolled conditions. Mineral acids. Organic acid, oxidizers, Reacts with metals until reacted with epoxy.

None known

Hazardous polymerization will not occur.

### SECTION 11. TOXICOLOGICAL INFORMATION

#### Mixture Toxicity

#### Component Toxicity

84852-15-3 nonyl phenol  
Oral LD50: 1,300 mg/kg (Rat) Dermal LD50: 2,031 mg/kg (Rabbit)

## SDS SHEET - XPRESS B, CATALYST BLACK - US

Eyes: Irritant to the eyes. Corrosive to Eyes  
 Skin: Irritant to the skin. Corrosive to Skin  
 Inhalation: Irritant to respiratory tract. Prolonged or excessive inhalation may cause respiratory tract irritation.  
 Sensitization: Skin sensitization in humans.

Eyes      Respiratory System

### Effects of Overexposure

<u>CAS Number</u>	<u>Description</u>	<u>% Weight</u>	<u>Carcinogen Rating</u>
1333-86-4	Black Pigment	0.1% - 1.0%	Black Pigment: NIOSH: potential occupational carcinogen IARC: Possible human carcinogen OSHA: listed

Avoid breathing vapors

Oral: N.D.A.  
 Dermal: N.D.A.  
 Inhalation: N.D.A.

### SECTION 12. ECOLOGICAL INFORMATION

No ecotoxicity data was found for the product

#### Component Ecotoxicity

nonyl phenol      96 Hr LC50 Pimephales promelas: 0.135 mg/L [flow-through]; 96 Hr LC50 Lepomis macrochirus: 0.1351 mg/L [flow-through]  
 48 Hr EC50 Daphnia magna: 0.14 mg/L  
 96 Hr EC50 Pseudokirchneriella subcapitata: 0.36 - 0.48 mg/L [static]; 72 Hr EC50 Pseudokirchneriella subcapitata: 0.16 - 0.72 mg/L [static]; 72 Hr EC50 Desmodesmus subspicatus: 1.3 mg/L

### SECTION 13. DISPOSAL INFORMATION

Dispose of in accordance with applicable local/municipal, state/provincial and federal regulations.

### SECTION 14. TRANSPORT INFORMATION

**UN proper shipping name:** Amines, liquid, corrosive, n.o.s.  
**Transportation Hazardous Shipping Class:** 8  
**UN number:** UN2735  
**Packing Group:** II  
**Hazardous label:** 8 Corrosive Substance  
**Environmental hazards-marine pollutant:** Yes

<u>Agency</u>	<u>Proper Shipping Name</u>	<u>UN Number</u>	<u>Packing Group</u>	<u>Hazard Class</u>
---------------	-----------------------------	------------------	----------------------	---------------------

### SECTION 15. REGULATORY INFORMATION

OSHA:29 CFR 1910.1200 Hazardous Chemical "Irritant", Sensitizer  
 TSCA: Ingredients listed  
 SARA III: Sec311 & 312 Immediate Health Hazard; Sec313 Chemicals above de minimus level: None  
 CA PROP. 65 NOTICE WARNING:

#### CANADIAN REGULATORY INFORMATION

WHMIS; Hazard Classification: D2B Skin Sensitizer. Refer to SDS for specific warnings  
 WHMIS Symbols: Stylized T.  
 WHMIS Trade Secret Registry Numbers: None  
 Hazardous Products Act Information: This product SDS contains ingredients which are Controlled and/or on the Ingredient Disclosure List

## SDS SHEET - XPRESS B, CATALYST BLACK - US

(HPA sections 13 and 14).

Country

Regulation

All Components Listed

### SECTION 16. ADDITIONAL INFORMATION

#### Hazardous Material Information System (HMIS)

HEALTH	<input type="text"/>	3
FLAMMABILITY	<input type="text"/>	1
PHYSICAL HAZARD	<input type="text"/>	1
PERSONAL PROTECTION	<input type="text"/>	

#### HMIS & NFPA Hazard Rating

##### Legend

\* = Chronic Health Hazard

0 = INSIGNIFICANT

1 = SLIGHT

2 = MODERATE

3 = HIGH

#### National Fire Protection Association (NFPA)

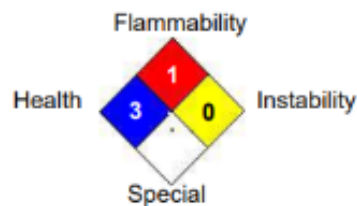

Date Revised: 8/8/2023

Date Prepared: 7/27/2023

Reviewer Revision

## SDS SHEET - XPRESS A, BASE WHITE - EUROPE



### SAFETY DATA SHEET

PICOTE BRUSH COATING™ EPOXY RESIN  
XPRESS A (COLOR: WHITE)

Revision date: 8-9-2023

#### SAFETY DATA SHEET

#### SECTION 1. IDENTIFICATION

Product Name: PICOTE Approved 3/29/23 Express 1:1 Product Code: XPRESS A  
Picote Solutions EMERGENCY CONTACT:  
20810 SE 18th PL +358 41 545 9054  
Sammamish, WA 98075

#### SECTION 2. HAZARD(S) IDENTIFICATION

##### GHS Ratings:

Skin corrosion/irritation	3	Reversible adverse effects in dermal tissue, Draize score: >= 1.5 < 2.3
Skin sensitization	1	Skin sensitizer
Carcinogenicity	2	Limited evidence of human or animal carcinogenicity

##### GHS Hazards

H316	Causes mild skin irritation
H317	May cause an allergic skin reaction
H351	Suspected of causing cancer

##### GHS Precautions

P201	Obtain special instructions before use
P202	Do not handle until all safety precautions have been read and understood
P261	Avoid breathing dust/fume/gas/mist/vapours/spray
P272	Contaminated work clothing should not be allowed out of the workplace
P280	Wear protective gloves/protective clothing/eye protection/face protection
P281	Use personal protective equipment as required
P321	Specific treatment (see ... on this label)
P363	Wash contaminated clothing before reuse
P302+P352	IF ON SKIN: Wash with soap and water
P308+P313	IF exposed or concerned: Get medical advice/attention
P332+P313	If skin irritation occurs: Get medical advice/attention
P333+P313	If skin irritation or a rash occurs: Get medical advice/attention
P405	Store locked up
P501	Dispose of contents/container to ...

Signal Word: Warning



#### SECTION 3. COMPOSITION/INFORMATION ON INGREDIENTS

Chemical Name	CAS number	Weight Concentration %
Epoxy Resin	25085-99-8	70.00% - 80.00%
Titanium Dioxide	13463-67-7	10.00% - 20.00%
Proprietary	68609-97-2	5.00% - 10.00%
Silica	67762-90-7	1.00% - 5.00%



## SDS SHEET - XPRESS A, BASE WHITE - EUROPE

### SECTION 4. FIRST AID MEASURES

If inhaled remove to fresh air. If breathing is difficult, give oxygen. Obtain medical advice if there are persistent symptoms

Rinse immediately with plenty of water for at least 15 minutes. Ensure adequate flushing of the eyes by separating the eyelids with fingers. Remove contacts if present and easy to do. Continue Rinsing. Get medical attention, if irritation or symptoms of overexposure persists.

Immediately wash skin with soap and plenty of water.

If swallowed, call a physician immediately. Only induce vomiting at the instruction of a physician. Never give anything by mouth to an unconscious person

### SECTION 5. FIRE FIGHTING MEASURES

Flash Point: 252 C (486 F)

LEL: N/A

UEL: N/A

Not applicable

Foam, Carbon dioxide (CO<sub>2</sub>) or dry chemical or water spray (water stream may be ineffective).

No information available

Not available

Firefighters, and others exposed, wear self-contained breathing apparatus.

### SECTION 6. ACCIDENTAL RELEASE MEASURES

Stop leak. Dike or contain spill. Pump into slavage tanks and/or absorb with suitable material. Use sparkless shovel to remove material. Evacuate area and keep unnecessary and unprotected personnel from entering the spill area.

Use appropriate containment and clean up immediately.

Stop leak, Dike and contain spill. Prevent spilled material from entering the ground, water and/or air by using appropriate containment methods.

### SECTION 7. HANDLING and STORAGE

Avoid breathing vapor. Avoid contact with eyes, skin and clothing. Keep away from heat and flame. Keep container closed. Use with adequate ventilation. Wash thoroughly after handling.

Avoid exposure to heat, light, and air for prolonged periods of time. Store in a cool, dry well ventilated area away from sources of heat and incompatible materials. Eliminate all ignition materials and incompatible materials.

Collect spill with non spark tools.

No information available.

### SECTION 8. EXPOSURE CONTROLS, PERSONAL PROTECTION

Chemical Name / CAS No.	OSHA Exposure Limits	ACGIH Exposure Limits	Other Exposure Limits
Epoxy Resin 25085-99-8	Not Established	Not Established	Not Established
Titanium Dioxide 13463-67-7	15 mg/m <sup>3</sup> TWA (total dust)	10 mg/m <sup>3</sup> TWA	Not Established
Proprietary 68609-97-2	Not Established	Not Established	Not Established
Silica 67762-90-7	Not Established	Not Established	Not Established

Use appropriate engineering control such as process enclosures, local exhaust ventilation, or other engineering controls to control airborne levels below recommended exposure limits. Good general ventilation should be sufficient to control airborne levels. Where

# PICOTE XPRESS RESIN SYSTEM

Version:  
January 16, 2024

## SDS SHEET - XPRESS A, BASE WHITE - EUROPE

such systems are not effective wear suitable personal protective equipment, which preforms satisfactory and meets OSHA or other recognized standards. Consult with local procedures for selection, training, and maintenance of the personal protective equipment Always use adequate ventilation that comply with local regulations.

**Eye/face Protection:** Wear appropriate protective glasses or splash goggles as described by 29 CFR 1910.133, OSHA eye and face protection regulation, or the European standard EN 168

**Skin Protection:** Chemical-resistant gloves and chemical goggles, face-shield and synthetic apron or coveralls should be used to prevent contact with eyes, skin or clothing.

**Respiratory Protection:** A NIOSH air purifying respirator with an organic vapor cartridge or canister may be permissible under certain circumstances where airborne concentrations are expected to exceed exposure limits. Protection provided by air purifying respirators is limited. Use a positive pressure air supplied respirator if there is any potential for an uncontrolled release, exposure levels are not known or any other circumstance where air purifying respirator may not provide adequate protection.

### SECTION 9. PHYSICAL and CHEMICAL PROPERTIES

<b>Boiling Range</b> 2500 to 3000 °C	<b>Specific Gravity (SG)</b> 1.258
<b>Lbs VOC/Gallon Less Water</b> 0.00	<b>Lbs VOC/Gallon Less</b> 0.00 <b>Exempt</b>
<b>% VOL by Volume</b> 0.00	

### SECTION 10. STABILITY and REACTIVITY

Stable, Hazardous polymeraization will not occur.

STABLE

Strong acids, caustics, oxidixers, Avoid uncontrolled exposure to Epoxy Resin, Amine.

No Data Found

None known, other than Sec. #2 and Sec #5

Hazardous polymerization will not occur.

### SECTION 11. TOXICOLOGICAL INFORMATION

**Mixture Toxicity**  
**Component Toxicity**

No Data Found

Respiratory System

**Effects of Overexposure**

CAS Number  
13463-67-7

Description  
Titanium Dioxide

% Weight  
10% - 20%

Carcinogen Rating  
Titanium Dioxide: NIOSH:  
potential occupational carcinogen  
IARC: Possible human carcinogen  
OSHA: listed

Avoid breathing vapors

Oral: N.D.A.  
Dermal: N.D.A.  
Inhalation: N.D.A.

## SDS SHEET - XPRESS A, BASE WHITE - EUROPE

### SECTION 12. ECOLOGICAL INFORMATION

No ecotoxicity data was found for the product

Component Ecotoxicity

### SECTION 13. DISPOSAL INFORMATION

Dispose of in accordance with applicable local/municipal, state/provincial and federal regulations.

### SECTION 14. TRANSPORT INFORMATION

UN3082 Environmentally Hazardous Substance, Liquid N.O.S. (Epoxy Resin)

Packaging Group III:

Hazardous Class 9

Agency	Proper Shipping Name	UN Number	Packing Group	Hazard Class
--------	----------------------	-----------	---------------	--------------

### SECTION 15. REGULATORY INFORMATION

OSHA:29 CFR 1910.1200 Hazardous Chemical "Irritant", Sensitizer

Country	Regulation	All Components Listed
---------	------------	-----------------------

### SECTION 16. ADDITIONAL INFORMATION

#### Hazardous Material Information System (HMIS)

HEALTH	2
FLAMMABILITY	1
PHYSICAL HAZARD	0
PERSONAL PROTECTION	C

#### HMIS & NFPA Hazard Rating Legend

\* = Chronic Health Hazard  
 0 = INSIGNIFICANT  
 1 = SLIGHT  
 2 = MODERATE  
 3 = HIGH

#### National Fire Protection Association (NFPA)

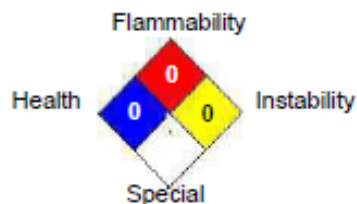

Date Revised: 8/8/2023

Date Prepared: 7/27/2023

Reviewer Revision

## SDS SHEET - XPRESS B, CATALYST BLACK - EUROPE



### SAFETY DATA SHEET

PICOTE BRUSH COATING™ EPOXY RESIN  
XPRESS B (COLOR: BLACK)

Revision date: 8-9-2023

#### SAFETY DATA SHEET

#### SECTION 1. IDENTIFICATION

Product Name: ACTIVATOR Approved 3/29/23 Express 1:1 Product Code: XPRESS B

Picote Solutions  
20810 SE 18th PL  
Sammamish, WA 98075

**EMERGENCY CONTACT EU : +358 41 545 9054**

#### SECTION 2. HAZARD(S) IDENTIFICATION

##### GHS Ratings:

Skin corrosion/irritation	1B	Destruction of dermal tissue: Exposure < 1 hour Observation < 14 days, visible necrosis in at least one animal
Serious eye damage/eye irritation	1	Serious eye damage: Irreversible damage 21 days after exposure, Draize score: Corneal opacity >= 3, Iritis > 1.5
Skin sensitization	1	Skin sensitizer
Carcinogenicity	2	Limited evidence of human or animal carcinogenicity
Reproductive toxicity	2	Human or animal evidence possibly with other information

##### GHS Hazards

H314	Causes severe skin burns and eye damage
H317	May cause an allergic skin reaction
H318	Causes serious eye damage
H351	Suspected of causing cancer
H361	Suspected of damaging fertility or the unborn child

##### GHS Precautions

P201	Obtain special instructions before use
P202	Do not handle until all safety precautions have been read and understood
P260	Do not breathe dust/fume/gas/mist/vapours/spray
P261	Avoid breathing dust/fume/gas/mist/vapours/spray
P264	Wash ... thoroughly after handling
P272	Contaminated work clothing should not be allowed out of the workplace
P280	Wear protective gloves/protective clothing/eye protection/face protection
P281	Use personal protective equipment as required
P310	Immediately call a POISON CENTER or doctor/physician
P321	Specific treatment (see ... on this label)
P363	Wash contaminated clothing before reuse
P301+P330+P331	IF SWALLOWED: Rinse mouth. Do NOT induce vomiting
P302+P352	IF ON SKIN: Wash with soap and water
P303+P361+P353	IF ON SKIN (or hair): Remove/Take off immediately all contaminated clothing. Rinse skin with water/shower
P304+P340	IF INHALED: Remove victim to fresh air and keep at rest in a position comfortable for breathing
P305+P351+P338	IF IN EYES: Rinse continuously with water for several minutes. Remove contact lenses if present and easy to do – continue rinsing
P308+P313	IF exposed or concerned: Get medical advice/attention
P333+P313	If skin irritation or a rash occurs: Get medical advice/attention
P405	Store locked up
P501	Dispose of contents/container to ...

## SDS SHEET - XPRESS B, CATALYST BLACK - EUROPE

Signal Word: Danger



### SECTION 3. COMPOSITION/INFORMATION ON INGREDIENTS

Chemical Name	CAS number	Weight Concentration %
Aminoethyl) piperazine, 1-(2-, (AEP)	140-31-8	80.00% - 90.00%
nonyl phenol	84852-15-3	5.00% - 10.00%
Amine	217-168-8	5.00% - 10.00%
Inert	INERT	1.00% - 5.00%
Black Pigment	1333-86-4	0.10% - 1.00%

### SECTION 4. FIRST AID MEASURES

If inhaled remove to fresh air. If breathing is difficult, give oxygen. Obtain medical advice if there are persistent symptoms

Rinse immediately with plenty of water for at least 15 minutes. Ensure adequate flushing of the eyes by separating the eyelids with fingers. Remove contacts if present and easy to do. Continue Rinsing. Get medical attention, if irritation or symptoms of overexposure persists.

Immediately wash skin with soap and plenty of water.

If swallowed, call a physician immediately. Only induce vomiting at the instruction of a physician. Never give anything by mouth to an unconscious person

### SECTION 5. FIRE FIGHTING MEASURES

Flash Point: N/A

LEL: N/A

UEL: N/A

Not applicable

Foam, Carbon dioxide (CO<sub>2</sub>) or dry chemical or water spray (water stream may be ineffective).

No information available

Not available

Firefighters, and others exposed, wear self-contained breathing apparatus.

### SECTION 6. ACCIDENTAL RELEASE MEASURES

Stop leak. Dike or contain spill. Pump into slavage tanks and/or absorb with suitable material. Use sparkless shovel to remove material. Evacuate area and keep unnecessary and unprotected personnel from entering the spill area.

Use appropriate containment and clean up immediately.

Corrosive. Avoid personal contact and breathing vapor or mist. Stop leak, Dike and contain spill. Prevent spilled material from entering the ground, water and/or air by using appropriate containment methods.

### SECTION 7. HANDLING and STORAGE

Avoid breathing vapor. Avoid contact with eyes, skin and clothing. Keep away from heat and flame. Keep container closed. Use with adequate ventilation. Wash thoroughly after handling.

Avoid exposure to heat, light, and air for prolonged periods of time. Store in a cool, dry well ventilated area away from sources of heat and incompatible materials. Eliminate all ignition materials and incompatible materials.

Collect spill with non spark tools.

No information available.

### SECTION 8. EXPOSURE CONTROLS, PERSONAL PROTECTION

# PICOTE XPRESS RESIN SYSTEM

Version:  
January 16, 2024

## SDS SHEET - XPRESS B, CATALYST BLACK - EUROPE

Chemical Name / CAS No.	OSHA Exposure Limits	ACGIH Exposure Limits	Other Exposure Limits
Aminoethyl) piperazine, 1-(2-, (AEP) 140-31-8	Not Established	Not Established	Not Established
nonyl phenol 84852-15-3	Not Established	Not Established	Not Established
Amine 217-168-8	Not Established	Not Established	Not Established
Inert INERT	Not Established	Not Established	Not Established
Black Pigment 1333-86-4	3.5 mg/m <sup>3</sup> TWA	3 mg/m <sup>3</sup> TWA (inhalable fraction)	NIOSH: 3.5 mg/m <sup>3</sup> TWA; 0.1 mg/m <sup>3</sup> TWA (Carbon black in presence of Polycyclic aromatic hydrocarbons, as PAH)

Use appropriate engineering control such as process enclosures, local exhaust ventilation, or other engineering controls to control airborne levels below recommended exposure limits. Good general ventilation should be sufficient to control airborne levels. Where such systems are not effective wear suitable personal protective equipment, which performs satisfactory and meets OSHA or other recognized standards. Consult with local procedures for selection, training, and maintenance of the personal protective equipment. Always use adequate ventilation that comply with local regulations.

**Eye/Face Protection:** Wear appropriate protective glasses or splash goggles as described by 29 CFR 1910.133, OSHA eye and face protection regulation, or the European standard EN 166

**Skin Protection:** Chemical-resistant gloves and chemical goggles, face-shield and synthetic apron or coveralls should be used to prevent contact with eyes, skin or clothing.

**Respiratory Protection:** A NIOSH air purifying respirator with an organic vapor cartridge or canister may be permissible under certain circumstances where airborne concentrations are expected to exceed exposure limits. Protection provided by air purifying respirators is limited. Use a positive pressure air supplied respirator if there is any potential for an uncontrolled release, exposure levels are not known or any other circumstance where air purifying respirator may not provide adequate protection.

### SECTION 9. PHYSICAL and CHEMICAL PROPERTIES

Specific Gravity (SG) 0.988	Lbs VOC/Gallon Less Water 0.00
Lbs VOC/Gallon Less 0.00 Exempt	% VOL by Volume 0.00

### SECTION 10. STABILITY and REACTIVITY

Stable, Hazardous polymerization will not occur. Will react with Epoxy Resins especially at elevated temperatures

**STABLE**

Epoxy Resins under uncontrolled conditions. Mineral acids. Organic acid, oxidizers, Reacts with metals until reacted with epoxy.

None known

Hazardous polymerization will not occur.

### SECTION 11. TOXICOLOGICAL INFORMATION

#### Mixture Toxicity

#### Component Toxicity

84852-15-3 nonyl phenol  
Oral LD50: 1,300 mg/kg (Rat) Dermal LD50: 2,031 mg/kg (Rabbit)

## SDS SHEET - XPRESS B, CATALYST BLACK - EUROPE

Eyes: Irritant to the eyes. Corrosive to Eyes  
 Skin: Irritant to the skin. Corrosive to Skin  
 Inhalation: Irritant to respiratory tract. Prolonged or excessive inhalation may cause respiratory tract irritation.  
 Sensitization: Skin sensitization in humans.

Eyes      Respiratory System

### Effects of Overexposure

CAS Number	Description	% Weight	Carcinogen Rating
1333-86-4	Black Pigment	0.1% - 1.0%	Black Pigment: NIOSH: potential occupational carcinogen IARC: Possible human carcinogen OSHA: listed

Avoid breathing vapors

Oral: N.D.A.  
 Dermal: N.D.A.  
 Inhalation: N.D.A.

### SECTION 12. ECOLOGICAL INFORMATION

No ecotoxicity data was found for the product

#### Component Ecotoxicity

nonyl phenol	96 Hr LC50 Pimephales promelas: 0.135 mg/L [flow-through]; 96 Hr LC50 Lepomis macrochirus: 0.1351 mg/L [flow-through] 48 Hr EC50 Daphnia magna: 0.14 mg/L 96 Hr EC50 Pseudokirchneriella subcapitata: 0.36 - 0.48 mg/L [static]; 72 Hr EC50 Pseudokirchneriella subcapitata: 0.16 - 0.72 mg/L [static]; 72 Hr EC50 Desmodesmus subspicatus: 1.3 mg/L
--------------	--

### SECTION 13. DISPOSAL INFORMATION

Dispose of in accordance with applicable local/municipal, state/provincial and federal regulations.

### SECTION 14. TRANSPORT INFORMATION

UN proper shipping name: Amines, liquid, corrosive, n.o.s. (Benzene-1,3-Dimethanamine, 1,5-Pentanediamine, 2-Mthyl)

Transportation Hazardous Shipping Class: 8

UN number: UN2735

Packing Group: II

Hazardous label: 8 Corrosive Substance

Environmental hazards-marine pollutant: Yes

Agency	Proper Shipping Name	UN Number	Packing Group	Hazard Class
--------	----------------------	-----------	---------------	--------------

### SECTION 15. REGULATORY INFORMATION

OSHA:29 CFR 1910.1200 Hazardous Chemical "Irritant", Sensitizer

TSCA: Ingredients listed

SARA III: Sec311 & 312 Immediate Health Hazard; Sec313 Chemicals above de minimus level: None

CA PROP. 65 NOTICE WARNING:

#### CANADIAN REGULATORY INFORMATION

WHMIS: Hazard Classification: D2B Skin Sensitizer. Refer to SDS for specific warnings

WHMIS Symbols: Stylized T.

WHMIS Trade Secret Registry Numbers: None

Hazardous Products Act Information: This product SDS contains ingredients which are Controlled and/or on the Ingredient Disclosure List

## SDS SHEET - XPRESS B, CATALYST BLACK - EUROPE

(HPA sections 13 and 14).

Country

Regulation

All Components Listed

### SECTION 16. ADDITIONAL INFORMATION

#### Hazardous Material Information System (HMIS)

HEALTH	<input type="checkbox"/>	3
FLAMMABILITY	<input type="checkbox"/>	1
PHYSICAL HAZARD	<input type="checkbox"/>	1
PERSONAL PROTECTION	<input type="checkbox"/>	

**HMIS & NFPA Hazard Rating Legend**  
\* = Chronic Health Hazard  
0 = INSIGNIFICANT  
1 = SLIGHT  
2 = MODERATE  
3 = HIGH

#### National Fire Protection Association (NFPA)

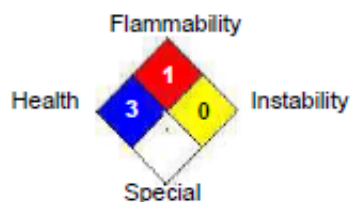

Date Revised: 8/8/2023

Date Prepared: 7/27/2023

Reviewer Revision