



Operating & Safety Manual

Smart Cutter™ Range



WARNING

These instructions are for your personal safety. Always ensure that you have read and understood these instructions before using any of the Smart Cutter™ range.



We now have resellers in the U.S., Europe & Australasia.

Locate your reseller at picotesolutions.com

TABLE OF CONTENTS

TOPIC	PAGE/S
SAFETY INFORMATION & SYMBOLS	3
AVAILABLE SIZES & POWER SOURCES	5
AVAILABLE MODEL TYPES	6
SMART CUTTER™ QUICK REFERENCE GUIDE	10
SMART CUTTER™ RANGE & USE	12
MAINTENANCE	26
PRACTICAL TIPS & SAFETY ADVICE	27
WARRANTY POLICY & PROCEDURE	28

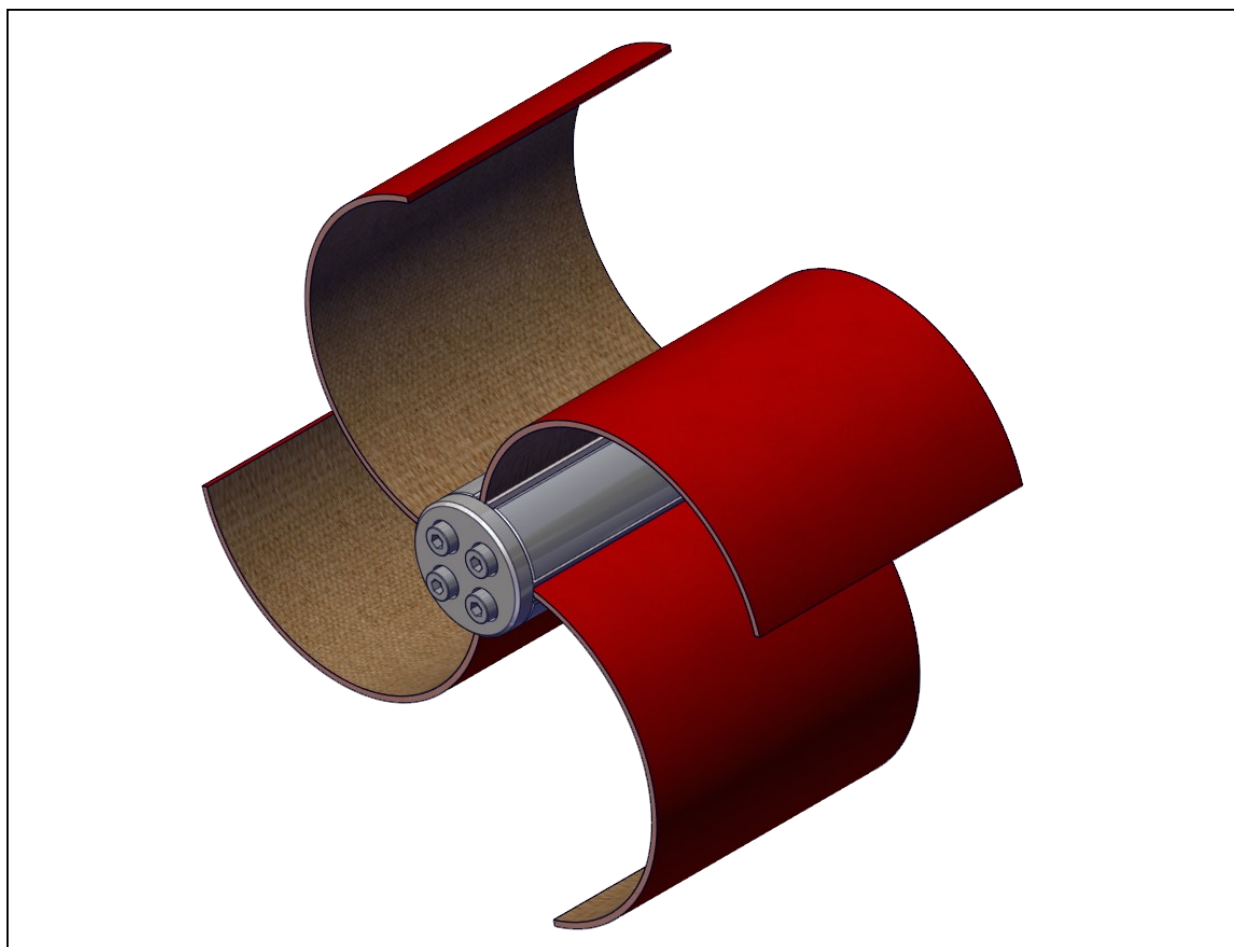

To watch practical demonstration videos, or to download an electronic copy of these Instructions, please visit www.picotesolutions.com. Please note that videos are not intended as a replacement or alternative to this operating and safety manual, but only as an additional learning tool.

SAFETY INFORMATION

WARNING

This section contains important safety information. Failure to comply could result in serious injury or death.

Safety Symbols

Safety symbols are used throughout this manual to draw attention to potential hazards.



Danger risk of serious injury, follow instructions



Danger risk of serious injury from rotating parts

Personal Protective Equipment (PPE)

Always use Personal Protective Equipment when using the Smart Cutter™, including suitable overalls / protective clothing & footwear and the following:



Always wear suitable eye protection when using the Smart Cutter™ to prevent sewage, chemicals or dust from irritating your eyes.



Always wear suitable ear protection when using the Smart Cutter™ to prevent any hearing loss.



Always wear suitable cut-resistant gloves when using the Smart Cutter™ to prevent any hand injuries. Any open injuries or skin irritations should be covered at all times to avoid contact with sewage, chemicals or dust.



Always wear a suitable respirator when using Smart Cutter™ to prevent any dust or fumes being inhaled or consumed, which can cause occupational asthma or dermatitis as well as eye irritation.

Always remember



Dust produced can be dangerous to your health, inflammable or explosive.

Make sure the pipe has been **opened** and **ventilated** to stop any gases forming in the lateral pipe where the work takes place.

Before assembly, use, replacement of parts or maintenance, unplug the Picote milling machine or your hand drill from its power socket.

SAVE ALL WARNINGS AND INSTRUCTIONS FOR FUTURE REFERENCE

⚠ WARNING *This section contains important safety information. Failure to comply could result in serious injury or death.*

ENVIRONMENTAL

Operational Ambient Temperature Range: -10...50 °C (14...122 °F) frost and condensation free

Storage Ambient Temperature Range: -20...60 °C (-4...140 °F) frost and condensation free

TRANSPORT

Picote tools should be transported in car or other vehicle properly secured to prevent any sudden movements caused by hard braking or accident. Using lidded boxes which are fastened and stored on the bottom of a van is recommended.

Never transport machine with tool attached to the shaft.

If using pick-up or trailer to transport Picote machine or tools, cover the products to protect them from raining water and dust.

STORAGE

It is recommended that tools are stored indoors protected from rain and sunlight and in constant ambient temperature.

If products have been stored for long periods of time (over 2-3 months), it should be checked and tested prior to use in field.

DISPOSAL

Smart Cutter™ metallic and plastic components can be separated and disposed separately as plastic and metal waste.

Always follow the local waste handling rules and regulation.

AVAILABLE SIZES & POWER SOURCES

The Smart Cutter™ is the most versatile tool produced by Picote. It can be equipped with a front drill head and a metal or plastic front grinding panel to both re-open reinstatements and gring the edges. It can be used as fine tuning tool to grind remaining edges after a connection has been reinstated using the Twister or Special Drill Head Cutter tools. The Smart Cutter™ can also be used to remove remaining lining or inconsistencies, after the collapsed lining has been removed using a Twister liner remover. Other uses are pipe cleaning in fragile or plastic pipes and metal grinding after Twister Metal Grinder has been used to cut metal inserts. The side grinding panels adapt to the pipe size when the tool is rotated.

Selecting the correct Smart Cutter™ for the job

Choose the correct Smart Cutter™ according to the size of the original host pipe.

Place the tool completely inside the pipe before powering up the tool.

Choose correct drill head for re-opening a connection.

In doubt, check the Picote Lateral Opening Quick Guides.

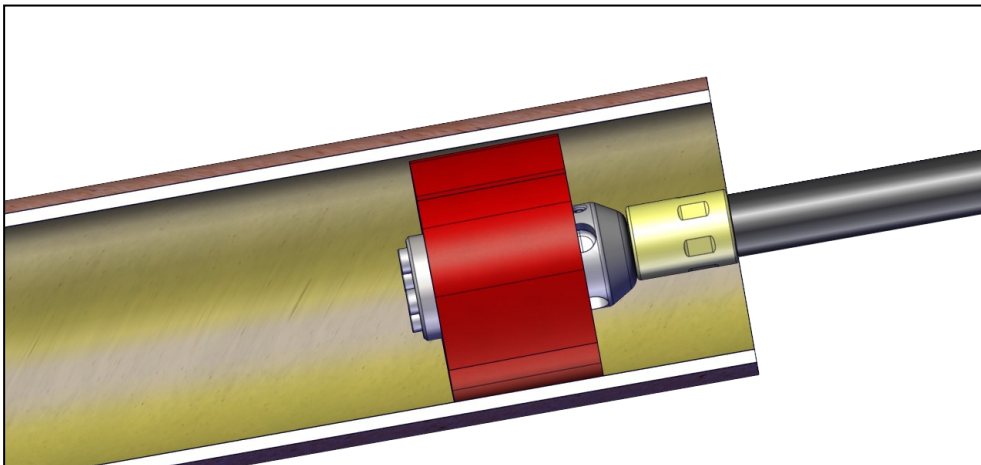

! WARNING



Pipe Size	Shaft size mm/inches	BEND 90°	BEND 45°
DN32 to DN40 (1.¼" to 1.½")	6 (¼") & 8 (⅓")	YES	YES
DN50 (2")	6 (¼") & 8 (⅓")	YES	YES
DN70 (3")	6 (¼") & 8 (⅓") & 12 (½")	YES	YES
DN100 (4")	12 (½")	YES	YES
DN125 (5")	12 (½")	YES	YES
DN150 (6")	12 (½")	YES	YES
DN200 (8")	12 (½")	YES	YES
DN225 (9")	12 (½")	YES	YES
DN250 (10")	12 (½")	YES	YES

CHOOSING YOUR POWER SOURCE

The Smart Cutter™ range has been designed to be operated with the **Picote Micro & Mini Miller & Mini Cleaner** with 8mm (1/3") shaft or **Midi & Maxi Miller** with 12mm (1/2") shaft or **Maxi Miller Power+** with 18mm (3/4"). They can be also operated with hand drill for lengths less than 10m (32ft). The Smart Cutters™ for 6mm shaft (1/4") are powered by hand drills. The operating procedures for the Smart Cutter™ for the **Maxi Miller Power+** are covered in a separate manual.

CHOOSING YOUR SMART CUTTER

Select the largest possible Smart Cutter™ for the job. Depending on the hub chosen the number of the grinding panels can vary between 2 to 6. Smart Cutters™ for Maxi Miller Power+ also has hubs for 6 and 8 panels. The larger number of grinding panels makes the tool more aggressive but also increases the load applied to the shaft and motor. When necessary the Smart Cutter can be guided through the pipe with the help of Steering Guides, Steering Wires, Weights and Hooks.

CHOOSING YOUR DRILL HEAD

The Smart Cutter can be used with or without the Front Metal Panel and drill head by replacing them with a Hub Disc. The Drill Head and Front Metal Panel are used when opening a connection in cast iron or clay pipes.

AVAILABLE MODEL TYPES

Smart Cutter™ with no wedge

The smallest Smart Cutters™ have been designed to operate in small pipe sizes from DN32 (1 1/4") to DN70 (3") or when there are dimensional changes in the pipe. Two panel hubs can be operated with the 6mm (1/4") or 8mm (1/3") shafts. Available with polishing panels as well.

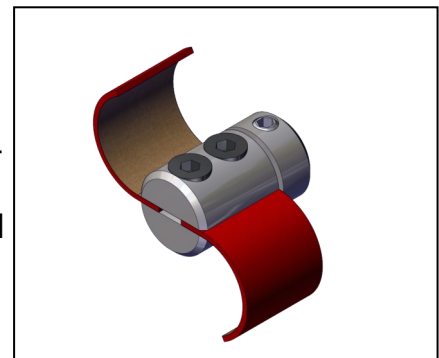

Benefits: Efficient, flexible and cost effective tool for general cleaning, descaling and grinding when other tools cannot be used because of access / space issues.

Name	Shaft size mm/inches	Pipe Size	Side Grinding Panel
HUB 8.5x20x60 No Wedge	8 (1/3")	DN50-DN75 (2"-3")	Side Grinding Panel No Wedge 50x100
HUB 8.5x20x40 No Wedge	8 (1/3")	DN50-DN75 (2"-3")	Side Grinding Panel No Wedge 40x60
HUB 6.5x15x40 No Wedge	6 (1/4")	DN32-DN50 (1 1/4"-2")	Side Grinding Panel No Wedge 40x60
HUB 6.5x15x30 No Wedge	6 (1/4")	DN32-DN50 (1 1/4"-2")	Side Grinding Panel 30x50
HUB 6.5x15x25 No Wedge	6 (1/4")	DN32-DN50 (1 1/4"-2")	Side Grinding Panel 25x40
HUB 6.5x12x25 No Wedge	6 (1/4")	DN32-DN50 (1 1/4"-2")	Side Grinding Panel 25x40

AVAILABLE MODEL TYPES

Smart Cutter™

Smart Cutter™ hubs with wedges are available with 2, 4 and 6 panels. They have been designed to operate in pipes up to DN200 (8"). Smart Cutters can be fitted with different drill heads which allow to both open a connection and grind the edges with the same tool. Smart Cutters™ are operated

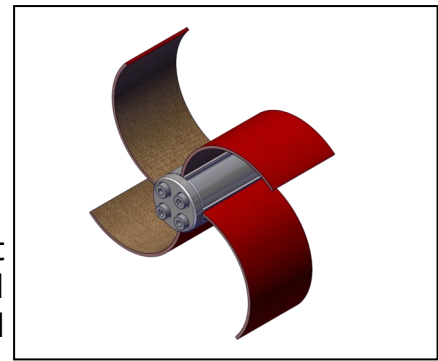

with 8mm (1/3") shafts from DN50 (2") to DN75 (3") and with 12mm (1/2") shaft from DN70 (3") to DN200 (8"). Different kinds of steering equipment can be used to guide the grinding tool.

Benefits: Efficient, flexible and cost effective tool for general cleaning, descaling and grinding with the possibility to combine drill head with the same tool.

Name	Shaft size mm/inches	Pipe Size	Side Grinding Panel
HUB 8.5x20x75 (2-panels)	8 (1/3")	DN50*—DN75 (2"—3")	Side Grinding Panel with Wedge 75x125
HUB 8.5x20x50 (2-panels)	8 (1/3")	DN50*—DN75 (2"—3")	Side Grinding Panel with Wedge 50x100
HUB 8.5x35x50 (4-panels) Available also in Aluminium	8 (1/3")	DN75 (3")	Side Grinding Panel with Wedge 50x100
HUB 12.5x40x200 (4-panels) Available also in Aluminium	12 (1/2")	DN150—DN200 (6"—8")	Side Grinding Panel with Wedge 200x300
HUB 12.5x40x150 (4-panels) Available also in Aluminium	12 (1/2")	DN100—DN150 (4"—6")	Side Grinding Panel with Wedge 150x100 Side Grinding Panel with Wedge 150x150
HUB 12.5x40x100 (4-panels) Available also in Aluminium	12 (1/2")	DN100—DN150 (4"—6")	Side Grinding Panel with Wedge 100x150
HUB 12.5x35x75 (4-panels) Available also in Aluminium	12 (1/2")	DN75—DN100 (3"—4")	Side Grinding Panel with Wedge 75x125
HUB 12.5x35x50 (4-panels) Available also in Aluminium	12 (1/2")	DN75—DN100 (3"—4")	Side Grinding Panel with Wedge 50x100
HUB 12.5x50x100 A (6-panels) for DN100 & DN150	12 (1/2")	DN100—DN150 (4"—6")	Side Grinding Panel with Wedge 100x100 for 6 panel hub
HUB 12.5x50x150 A (6-panels) for DN150 & DN200	12 (1/2")	DN150—DN200 (6"—8")	Side Grinding Panel with Wedge 150x150 Side Grinding Panel with Wedge 150x200

*Only in straight sections

AVAILABLE MODEL TYPES

Smart Cutter™ with different roughness panels

Smart Cutter™ hubs can be equipped with Regular, XT Rough or Polishing Panels. Polishing panels have smoother surface texture compared to regular Side Grinding Panels which make them perfect tools to finalize any connection edges. XT Rough panels are best suited for removing stubborn scale and finalizing cleaning after liner or concrete removal.

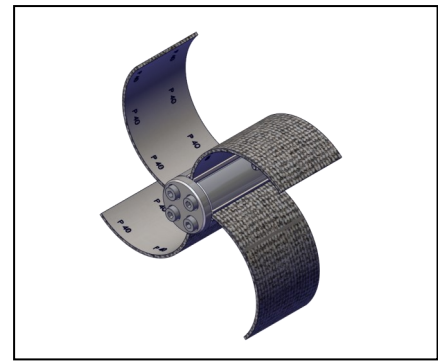

Benefits: Choose the grinding panel best suited for your application.

Name	Shaft size mm/inches	Pipe Size	Polishing Panel
HUB 8.5x20x75 (2-panels)	8 (1/3")	DN50*-DN75 (2"-3")	Polishing Panel With Wedge 75X100
HUB 8.5x20x50 (2-panels)	8 (1/3")	DN50*-DN75 (2"-3")	Polishing Panel With Wedge 50X100
HUB 8.5x35x50 (4-panels) Available also in Aluminium	8 (1/3")	DN75 (3")	Polishing Panel With Wedge 50X100
HUB 12.5x40x150 (4-panels) Available also in Aluminium	12 (1/2")	DN100-DN150 (4"-6")	Polishing Panel With Wedge 150x200
HUB 12.5x40x100 (4-panels) Available also in Aluminium	12 (1/2")	DN100-DN150 (4"-6")	Polishing Panel With Wedge 100X125 Polishing Panel With Wedge
HUB 12.5x35x75 (4-panels) Available also in Aluminium	12 (1/2")	DN75-DN100 (3"-4")	Polishing Panel With Wedge 75X100
HUB 12.5x35x50 (4-panels) Available also in Aluminium	12 (1/2")	DN75-DN100 (3"-4")	Polishing Panel With Wedge 50X100
HUB 12.5x50x100 A (6-panels) for DN100 & DN150	12 (1/2")	DN100-DN150 (4"-6")	Polishing Panel With Wedge 100X125 Polishing Panel With Wedge
HUB 12.5x50x150 A (6-panels) for DN150 & DN200	12 (1/2")	DN150-DN200 (6"-8")	Polishing Panel With Wedge 150x200

*Only in straight sections

Refer to Mini Cleaner User Manual and Quick Guides to learn more about using polishing panels and small hubs in DN32 to DN40 (1.1/4" to 1.1/2") pipes.

AVAILABLE MODEL TYPES

Smart Cutter™ Drill Heads

Smart Cutter™ hubs with wedged side grinding panels can be equipped with different kind of grinding discs and drill heads to create a tool which can both open a connection and grind it at the same time without the need to change the tool in cast iron or clay pipes. This kind of combination

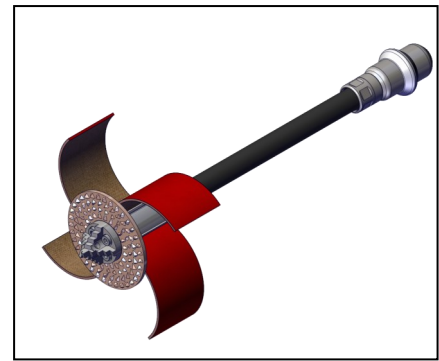

is also very effective for removing tree roots from the pipes. The front grinding discs are available in metal and plastic forms. Metal panel is more aggressive compared to the plastic panel. The diameter of the grinding discs is dependent on whether it is being used in a lined or unlined pipes (DN100 (4") and DN150 (6") pipe sizes). The smaller size plate should only be used in lined pipes.

Benefits: You can save time by using a drill head in the front of the Smart Cutter™ to quickly re-open connections and grind the edges without the need of tool change.

Pipe Size	Grinding Disc	Drill Head
DN75 (3")	Front Metal Panel 55 (2.2") 1mm g10 Front Plastic Panel 55 (2.2")	Front Drill Head 3 Ridged Hardened 35mm (1.4")
DN100 (4")	Front Metal Panel 75 (3") 1mm g10 Front Metal Panel 85 (3.3") 1mm g10 Front Plastic Panel 75 (3")	Front Drill Head 3 Ridged Hardened 35mm (1.4")
DN150 (6")	Front Metal Panel 115 (4.5") 1mm g10 Front Metal Panel 125 (5") 1mm g10	Front Drill Head 3 Ridged Hardened 35mm (1.4")
DN200 (8")	Front Metal Panel 175 (7") 1mm g10	Front Drill Head 3 Ridged Hardened 35mm (1.4")

SMART CUTTER™ QUICK REFERENCE GUIDE

6mm Diameter Shaft

Pipe DN	Hub Dimensions	Wedge	Number of Panels	Size of Panels	Hub Disc	Steering Hub Disc
32	6.5x12x25	No	2	40x60	No	No
32	6.5x15x25	No	2	40x60	No	No
32	6.5x15x30	No	2	40x60	No	No
32	6.5x15x40	No	2	40x60	No	No
40	6.5x12x25	No	2	40x60	No	No
40	6.5x15x25	No	2	40x60	No	No
40	6.5x15x30	No	2	40x60	No	No
40	6.5x15x40	No	2	40x60	No	No
50	6.5x12x25	No	2	40x60	No	No
50	6.5x15x25	No	2	40x60	No	No
50	6.5x15x30	No	2	40x60	No	No
50	6.5x15x40	No	2	40x60	No	No

8mm Diameter Shaft

Pipe DN	Hub Dimensions	Wedge	Number of Panels	Size of Panels	Hub Disc	Steering Hub Disc	Starter Kit
32	8.5x18x25	No	2	35x45	No	No	Mini Cleaner
40	8.5x18x25	No	2	40x50	No	No	Mini Cleaner
40	8.5x20x40	No	2	40x60	No	No	Yes
50	8.5x20x40	No	2	40x60	No	No	Yes
50	8.5x20x50	Yes	2	50x100	0x20x6	No	
50	8.5x20x60	No	2	50x100	No	No	
70	8.5x20x50	Yes	2	50x100	0x20x6	No	
70	8.5x20x60	No	2	50x100	No	No	
70	8.5x20x75	Yes	2	75x125	0x20x6	No	
70	8.5x35x50	Yes	4	50x100	0x35x6	10.5x35x6	Yes
100	8.5x20x75	Yes	2	75x125	0x20x6	No	
100	8.5x35x50	Yes	4	50x100	0x35x6	10.5x35x6	Yes

SMART CUTTER™ QUICK REFERENCE GUIDE

12mm Diameter Shaft

Pipe DN	Hub Dimensions	Wedge	Number of Panels	Size of Panels	Hub Disc	Steering Hub Disc	Starter Kit
70	12.5x35x50	Yes	4	50x100	0x35x6	10.5x35x6	Yes
70	12.5x35x75	Yes	4	75x125	0x35x6	10.5x35x6	Yes
100	12.5x35x50	Yes	4	50x100	0x35x6	10.5x35x6	Yes
100	12.5x35x75	Yes	4	75x125	0x35x6	10.5x35x6	Yes
100	12.5x40x100	Yes	4	100x150	0x40x6	10.5x40x6	Yes
100	12.5x40x150	Yes	4	150x100	0x40x6	10.5x40x6	Yes
100	12.5x50x100	Yes	6	100x100	0x50x3	No	
125	12.5x40x100	Yes	4	100x150	0x40x6	10.5x40x6	Yes
125	12.5x40x150	Yes	4	150x150	0x40x6	10.5x40x6	Yes
125	12.5x50x150	Yes	6	150x150	0x50x3	No	
150	12.5x40x100	Yes	4	100x150	0x40x6	10.5x40x6	Yes
150	12.5x40x150	Yes	4	150x150	0x40x6	10.5x40x6	Yes
150	12.5x40x150	Yes	4	150x200	0x40x6	10.5x40x6	Yes
150	12.5x40x150	Yes	4	150x150	0x40x6	10.5x40x6	Yes
150	12.5x40x200	Yes	4	200x300	0x40x6	10.5x40x6	Yes
150	12.5x50x150	Yes	6	150x150	0x50x3	No	
150	12.5x50x150	Yes	6	150x200	0x50x3	No	
200	12.5x40x150	Yes	4	150x200	0x40x6	10.5x40x6	Yes
200	12.5x40x150	Yes	4	150x250	0x40x6	10.5x40x6	Yes
200	12.5x40x200	Yes	4	200x300	0x40x6	10.5x40x6	Yes
200	12.5x50x150	Yes	6	150x200	0x50x3	No	
200	12.5x50x150	Yes	6	150x250	0x50x3	No	
225	12.5x40x150	Yes	4	150x250	0x40x6	10.5x40x6	Yes
225	12.5x40x200	Yes	4	200x300	0x40x6	10.5x40x6	Yes
225	12.5x50x150	Yes	6	150x250	0x50x3	No	
250	12.5x40x200	Yes	4	200x300	0x40x6	10.5x40x6	Yes

SMART CUTTER RANGE & USE



Please read safety information on page 3 before assembly and use.

Smart Cutter Hubs

6-panel

1001250100A	HUB 12.5x50x100 A 6 panel for DN100 & DN150
1001250150A	HUB 12.5x50x150 A 6 panel for DN150 & DN200

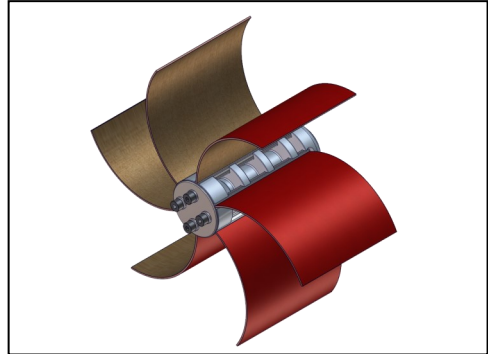

4-panel

1001240200A	HUB 12.5x40x200 Aluminum
1001240150A	HUB 12.5x40x150 Aluminum
1001240100A	HUB 12.5x40x100 Aluminum
1001235075A	HUB 12.5x35x75 Aluminum
1001235050A	HUB 12.5x35x50 Aluminum
1000835050A	HUB 8.5x35x50 Aluminum

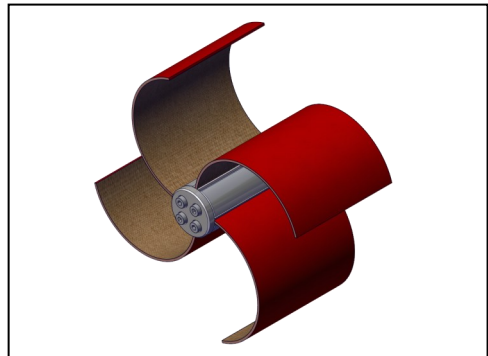

SMART CUTTER RANGE & USE



Please read safety information on page 3 before assembly and use.

Smart Cutter Hubs

2-panel

1000820075	HUB 8.5x20x75 2W
1000820050	HUB 8.5x20x50 2W
1000820060	HUB 8.5x20x60 No Wedge
1000820040	HUB 8.5x20x40 No Wedge
1000615040	HUB 6.5x15x40 No Wedge
1000615030	HUB 6.5x15x30 No Wedge
1000615025	HUB 6.5x15x25 No Wedge
1000612025	HUB 6.5x12x25 No Wedge



Hub Discs (without hole)

1000200050	HUB Disc 0x50x3 XL (6-blade)
1000200040	HUB DISC 0x40x6
1000200035	HUB DISC 0x35x6
1000200020	HUB DISC 0x20x6

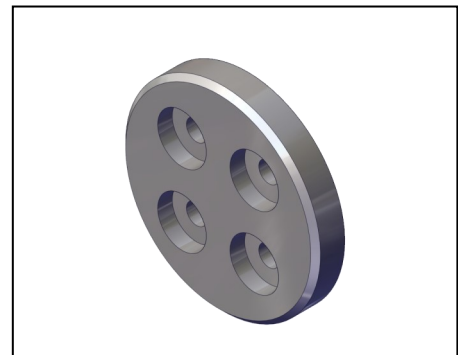

Steering Hub Discs (with hole)

1000210040	HUB DISC 10.5x40x6
1000210035	HUB DISC 10.5x35x6

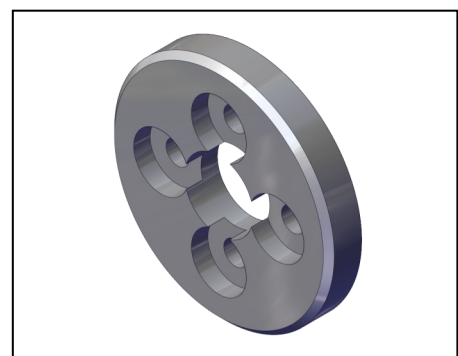

SMART CUTTER RANGE & USE



Please read safety information on page 3 before assembly and use.

Side Grinding Panels

Wedge

1202200300	Side Grinding Panel with Wedge 200x300
1202150250	Side Grinding Panel with Wedge 150x250
1202150200	Side Grinding Panel with Wedge 150x200
1202150150	Side Grinding Panel with Wedge 150x150
1202100150	Side Grinding Panel with Wedge 100x150
1202100100	Side Grinding Panel with Wedge 100x100 for 6 panel hub
1202075125	Side Grinding Panel with Wedge 75x125
1203050100	Side Grinding Panel with Wedge 50x100

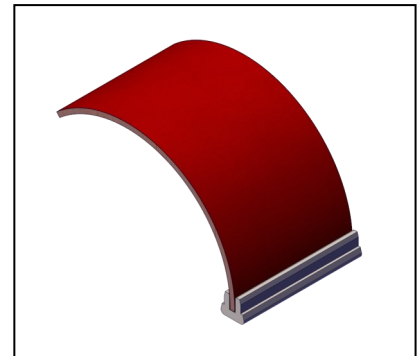

No Wedge

1202050100	Side Grinding Panel No Wedge 50x100
1202040060	Side Grinding Panel No Wedge 40x60

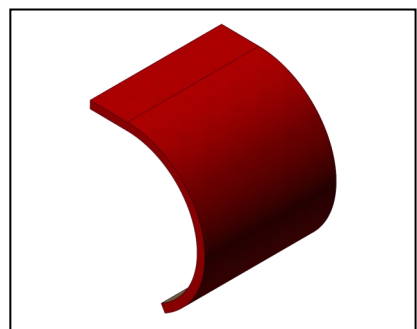

Polishing Panel

1241150200	Polishing Panel With Wedge 150x200 SPECIAL ORDER ONLY
1241100150	Polishing Panel With Wedge 100X150
1241100125	Polishing Panel With Wedge 100X125
1241075100	Polishing Panel With Wedge 75X100
1241050100	Polishing Panel With Wedge 50X100

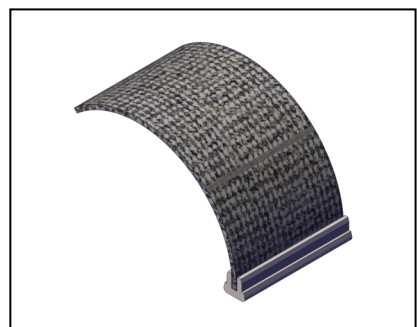

SMART CUTTER RANGE & USE



Please read safety information on page 3 before assembly and use.

Side Grinding Panels XT Rough

Wedge

1203200300	Side Grinding Panel XT Rough 200x300
1203150250	Side Grinding Panel XT Rough 150x250
1203150200	Side Grinding Panel XT Rough 150x200
1203150150	Side Grinding Panel XT Rough 150x150
1203100150	Side Grinding Panel XT Rough 100x150
1203100100	Side Grinding Panel XT Rough 100x100
1203075125	Side Grinding Panel XT Rough 75x125
1205050100	Side Grinding Panel XT Rough 50x100



No Wedge

1204050100	Side Grinding Panel XT Rough 50x100 no wedge
------------	--

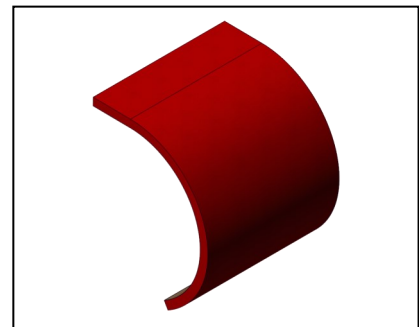

Mini Cleaner Panels

1202025040	Side Grinding Panel DN32 Package (25x40)
1202030050	Side Grinding Panel DN40 Package (30x50)
1202040060	Cleaning Panel DN32 Package (35x45)
1202050100	Cleaning Panel DN40 Package (40x50)



Note! Do not use grinding panels on pipe diameters less than DN50.

SMART CUTTER RANGE & USE



Please read safety information on page 3 before assembly and use.

Front Panels & Drill Heads

Front Metal Panel 1mm (grit 10)

1210310175	Front Metal Panel 175/7" 1mm g10
1210310125	Front Metal Panel 125/5" 1mm g10
1210310115	Front Metal Panel 115/4.5" 1mm g10
1210310085	Front Metal Panel 85/3.3" 1mm g10
1210310075	Front Metal Panel 75/3" 1mm g10
1210310055	Front Metal Panel 55/2.2" 1mm g10

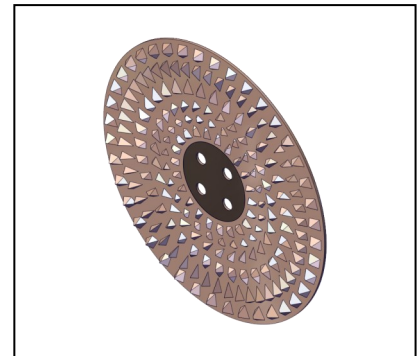

Front Plastic Panel

1220210125	Front Plastic Panel 125/5"
1220210085	Front Plastic Panel 85/3.3"
1220210075	Front Plastic Panel 75/3"
1220210055	Front Plastic Panel 55/2.2"

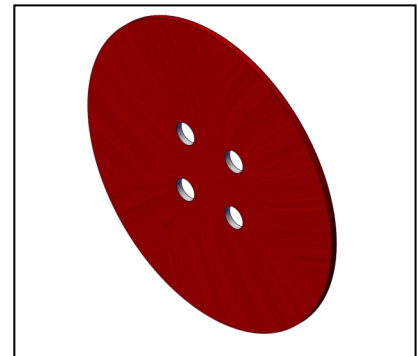

Front Drill Head

1300212035	Front Drill Head 3 Ridged Hardened 35mm/1.4"
------------	--

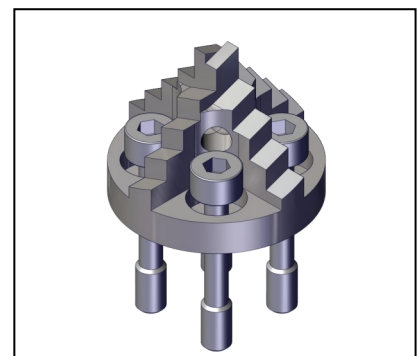

SMART CUTTER RANGE & USE



Please read safety information on page 3 before assembly and use.

Steering Axle & Fine Tuning Tools

1100100055	Steering Axle 55
1100200001	Bearing for Steering Axle
1312024125	Smart Steering Guide DN100/DN150 with bearing
1312025125	Smart Steering Guide DN150/DN200 with bearing
1100500040	Weight 40
1100500060	Weight 60
1350150405	Steering Wire 100m
1350000125	Wire Hook 12.5
1350000085	Wire Hook 8.5

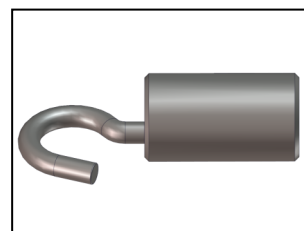
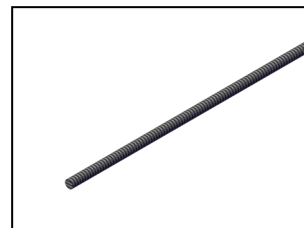
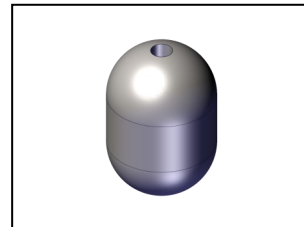
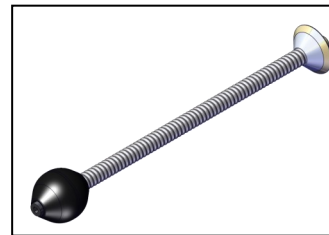
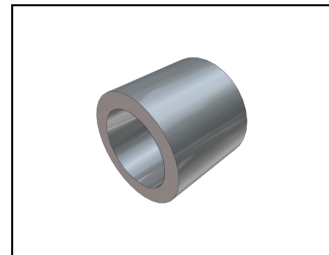
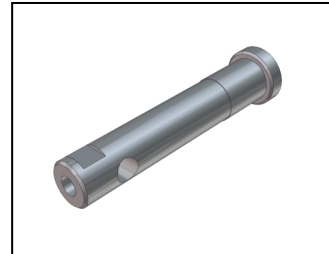

User Guide—Opening Connections

Step 1. Select the Smart Cutter™ equipped with metal or plastic panels and drill head according to the size of the host pipe. Place a CCTV camera into lined pipe so that you will see how the work is progressing. **Never work blind!**

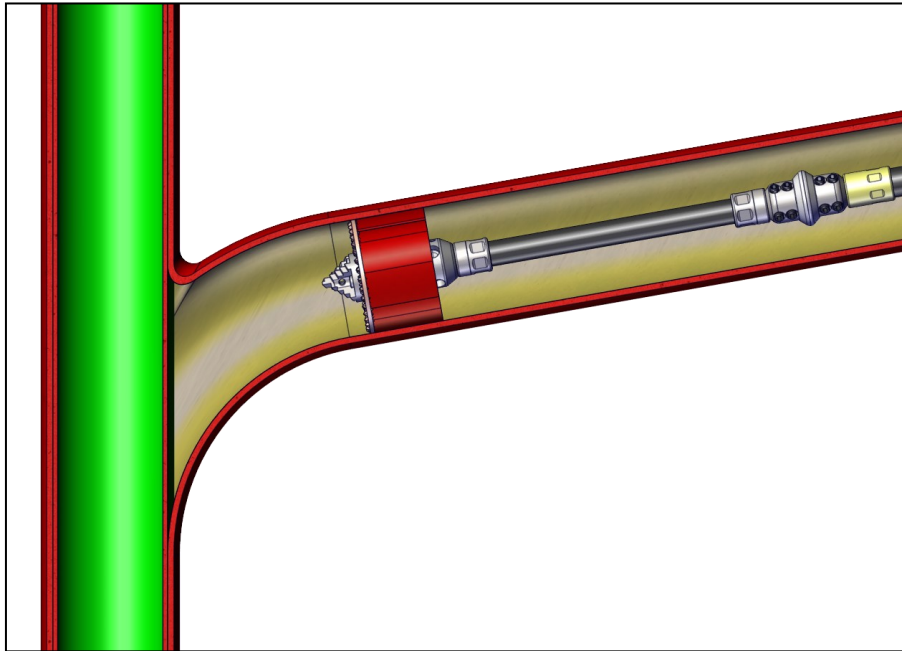
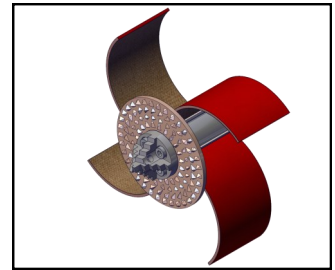

Step 2. Carefully drill the hole. Continue to push through so that you remove as much the liner away from the connection as possible. **Beware that you do not damage the already lined pipe during the process.** Use Smart Cutter™ grinding panels to grind the hole edges before removing the tool from the pipe.

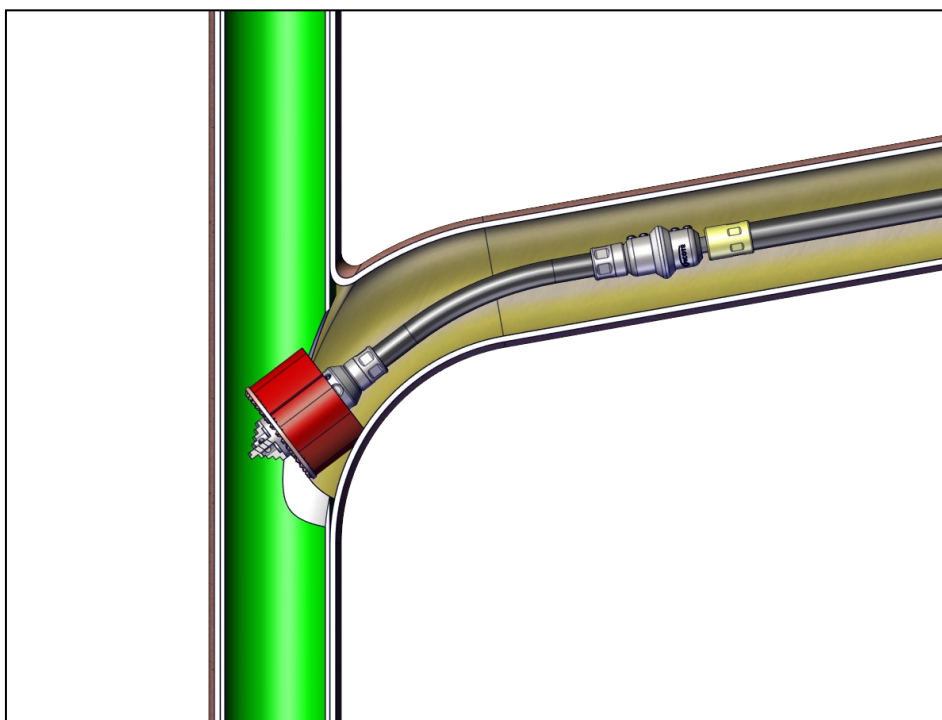

User Guide—Opening Connections

Tip! You can use Smart Cutter™ with Ball Steering Guide to focus the grinding force in locations where the connection is hardest to grind.

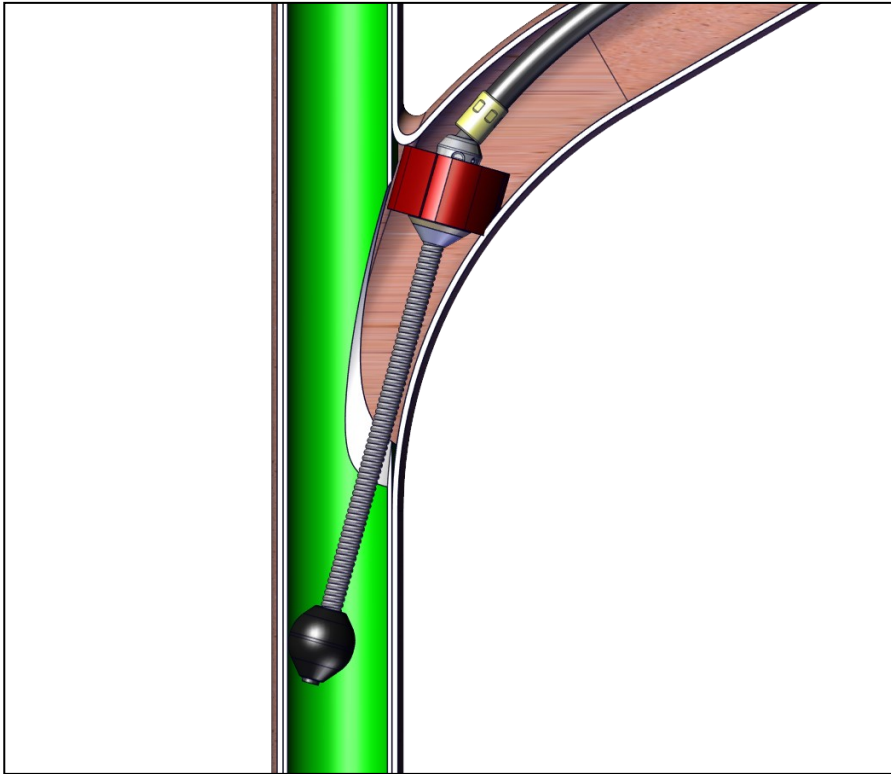
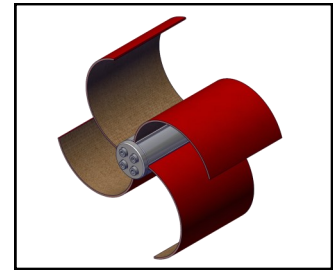

Step 3. It is recommended to use the lined Twister version when opening connections in already lined pipes. If Smart Cutter™ with drill head is used, you will damage the lined pipe during the opening process. Select the Twister according to the size of host pipe, for the job. Drill the connection open carefully. Push the Twister

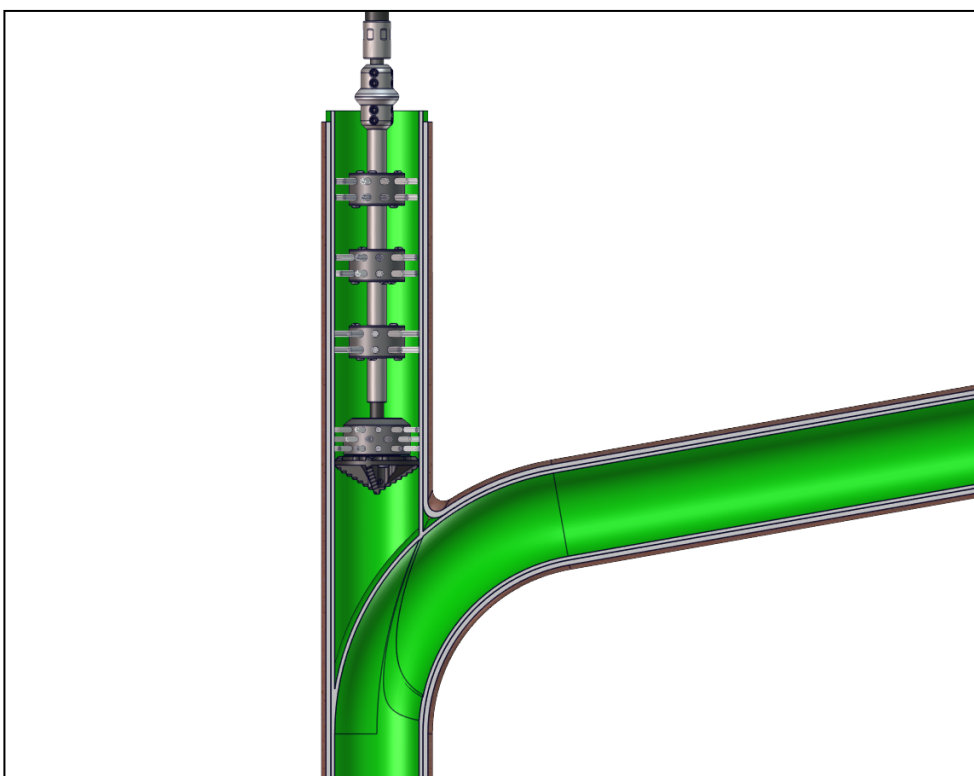

Tool Change—Smart Cutter™ (no wedge)

Remove Allen Bolts and change the worn out Side Grinding Panels with no Wedge. The red grinding side of the new panels needs to be positioned to the rotation direction (clockwise). Repeat assembly steps in reverse order to mount the panels. Tighten Allen Bolts evenly.

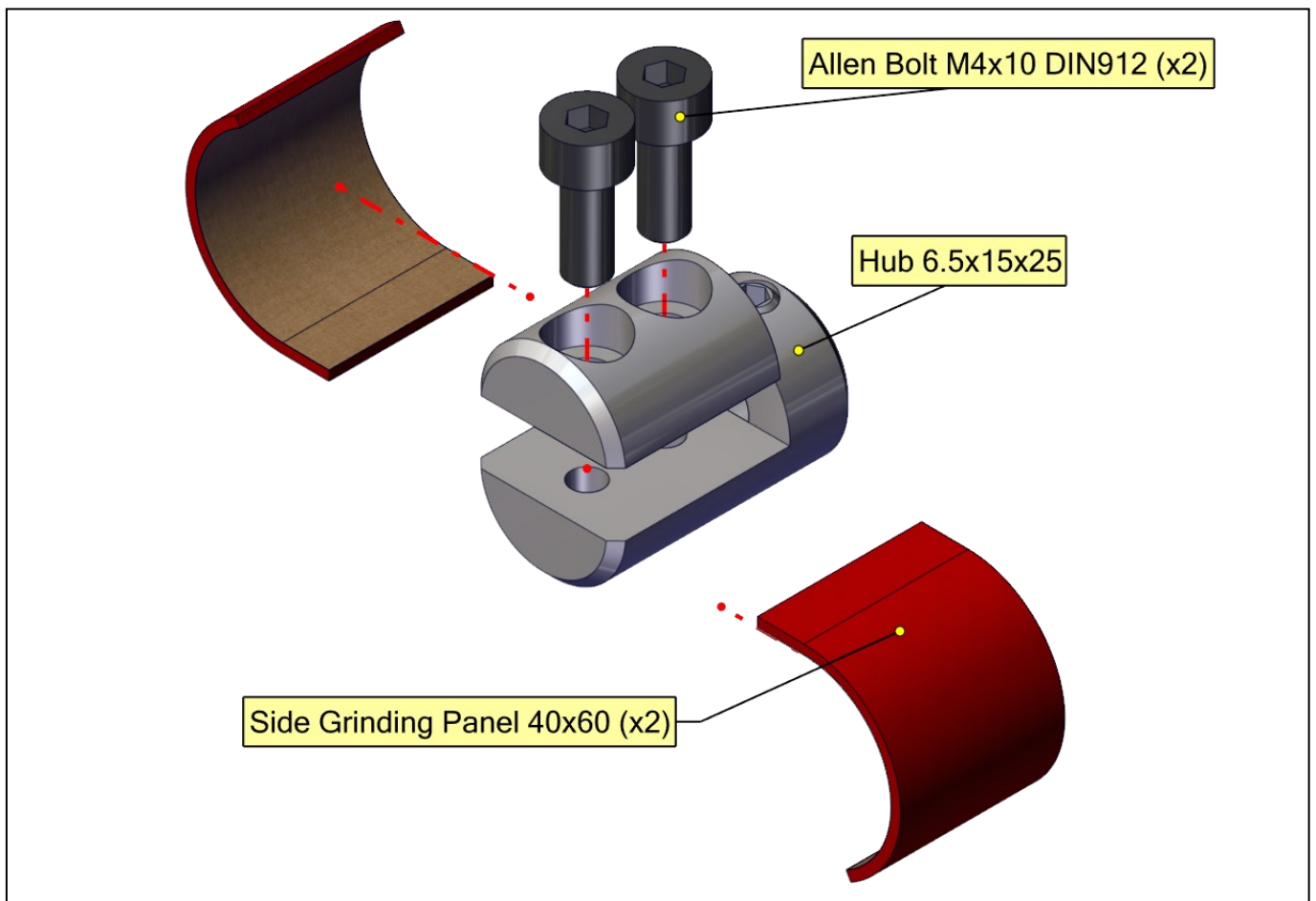
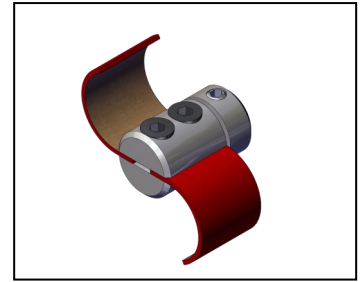

Tool Change—Smart Cutter™

Remove Allen Bolts and change the worn out Side Grinding Panels with Wedge. The red grinding side of the new panels needs to be positioned to the rotation direction (clockwise). Repeat assembly steps in reverse order to mount the panels. Tighten Allen Bolts evenly.

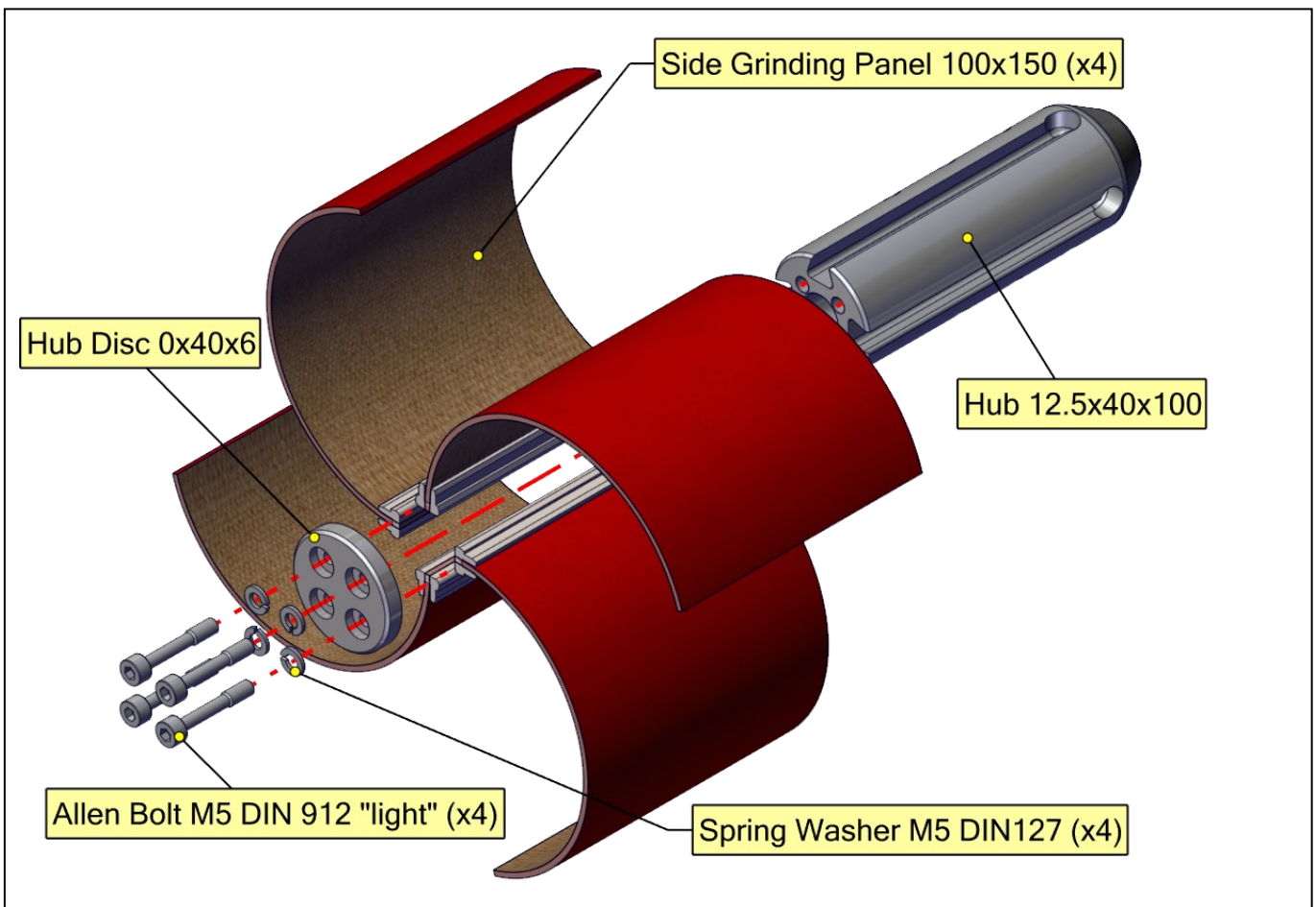
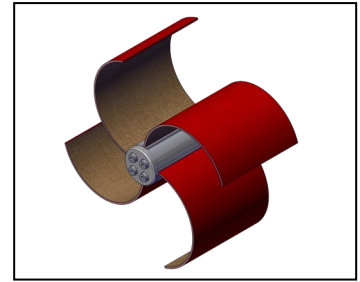

Tool Change—Smart Cutter™ (Front Drill Head Fitted)

Remove Allen Bolts and Spring Washers and change the worn out Side Grinding Panels with Wedge, Front Plastic Panels and Drill Head if needed. The red grinding side of the new panels needs to be positioned to the rotation direction (clockwise). Two Front Plastic Panels are needed. Place them backsides against each other as seen below. Tighten Allen Bolts evenly.

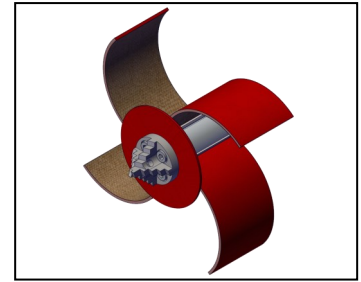

Recommended to use Loctite 542.

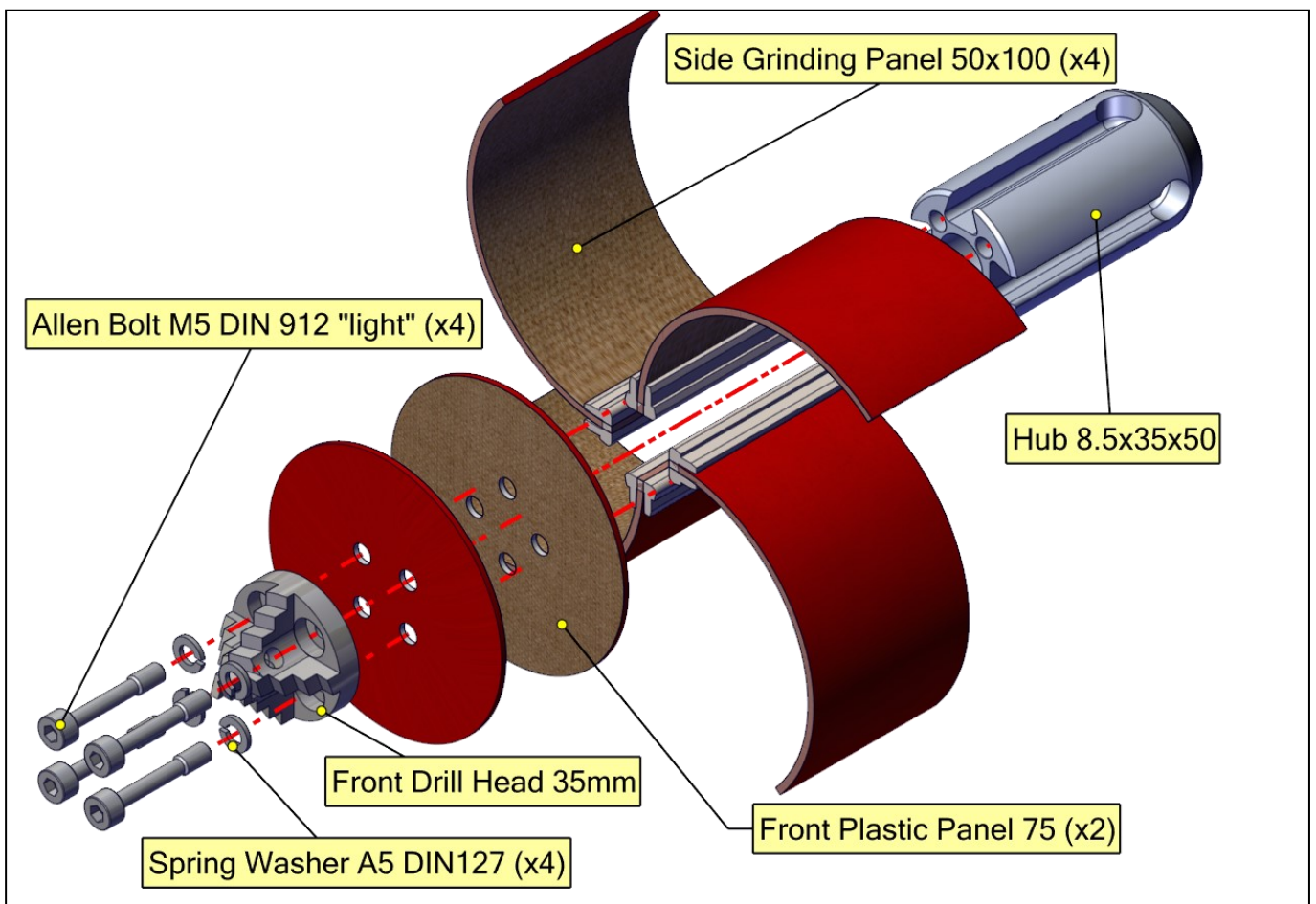

Tool Change—Smart Cutter™ (Front Drill Head Fitted)

Remove Allen Bolts and change the worn out Side Grinding Panels with Wedge, Front Metal Panel and Drill Head if needed. The red grinding side of the new panels needs to be positioned to the rotation direction (clockwise). Tighten Allen Bolts evenly.

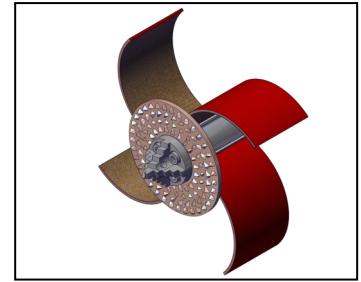

Recommended to use Loctite 542.

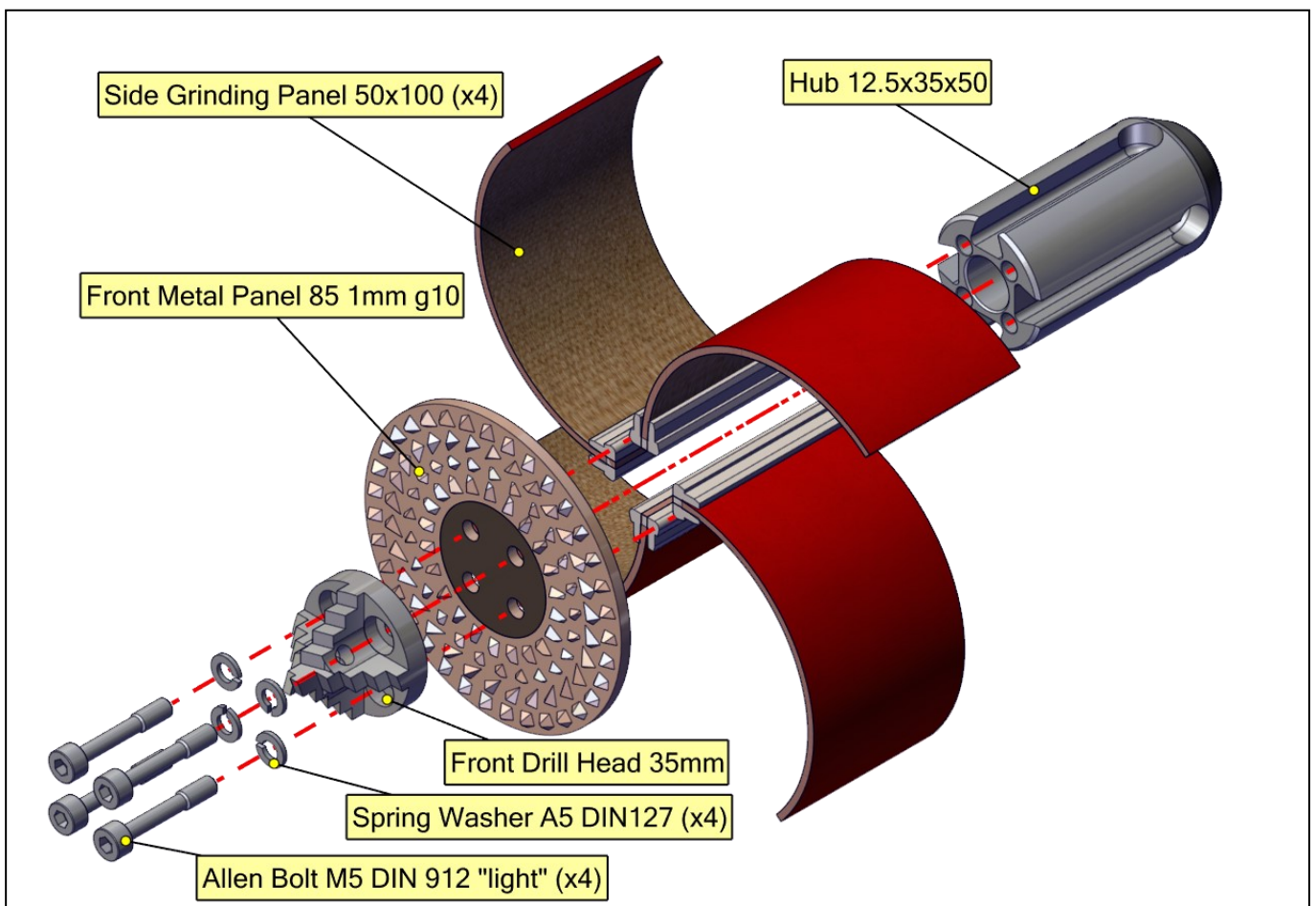

Using Smart Cutter™ Before work



Select the correct size of Smart Cutter™ for your job. Instructions for hub and grinding or polishing panel selection are in this manual pages 5-7. Ventilate the working site properly. Ensure that the pipes are grounded / earthed. Use CCTV camera to observe working.

Ensure water is flowing in the pipe or the vacuum extraction is ready (dry cleaning). Twist the grinding panels so that you create a tight roll and then place the tool into the pipe. Place the Smart Cutter™ completely inside the pipe before powering it up. Smart Cutters™ are a highly efficient tools for grinding the edges of connection and for cleaning the pipes after chains have been used. Although it is possible to perform dry grinding if necessary, it is advised that you use water when grinding with Smart Cutter™. Water flushes out all of the debris while you work and prevents build-up of debris which could lead to future blockages.

During use

Turn the power on. Move the tool constantly in back and forth movement during use. Clean the pipe in about 1m (2 to 3ft) sections starting from the far end of the pipe. After each section is cleaned, move back along the pipe and continue the cleaning process in next section. Always use CCTV camera inside the pipe to observe your progress. Adjust the speed while working. Hold shaft tightly. Be especially careful when working in plastic pipes or cleaning tight bends. The Smart Cutter™ can quickly generate enough friction heat that the plastic pipe could melt if the tooling is not moved back and forth constantly. In heavily scaled pipes, it is recommended to begin the work using the Original Chain and continue with Cyclone Chain. Use PVC models in plastic pipes. You can use the Smart Cutter™ to finish off the cleaning. When grinding the edges in re-opened connections, use CCTV camera to locate the tool to the correct position and grind as long as needed. You can use steering wires, hooks and weights to control and assist with the grinding.

Where the Smart Cutter™ is used for grinding leftover metal, after Twister Metal Grinder tool has been used, begin the process with lowest possible rotation speed. After you have round the sharp edges of metal inserts, you can use the maximum rotation speed. The Smart Cutter™ can be used to grind away internal pipe weld seams in the metal pipes to improve flow conditions through the pipe.



If water cooling is not used, keep breaks during work after every 30 min. **The tool head gets very hot during use when not water cooled. Touch only with heat resisted gloves.** Tool can be cooled down with water or let it cool in air. Observe the outer casing temperature.

Please read safety information on
page 3 before assembly and use.

Using Smart Cutter™



During use cont.

Do not push the tool with high force—let the tool do the work. If excessive force or high speeds are used the tool might get stuck or break the tool, shaft or the pipe. Use either water or vacuum to remove detached dirt.

After use

Be careful when removing the tool out from the pipe. **Always turn the power off before you remove the tool out from the pipe! There is a risk of serious injury or even death!**

Check out the condition of the tooling and shaft. Replace worn-out parts. If part of the shaft is damaged, it can be removed using a disc cutter and then shorten outer casing accordingly.

The Drill Head can be sharpened with rotating tool if needed. Do not remove more material than you must because the hard layer is only 2-3 mm thick.

RECOMMENDATIONS

When removing heavy scale from inside the pipe you need to use the Original Chains and then follow up with the Cyclone Chain. Use PVC models inside plastic pipes. To obtain the best results you need to finish off with the Smart Cutter™.

Do not power up the Smart Cutter™ products outside of the pipe! The tooling needs to fit completely inside the pipe before use.

Select the correct size Smart Cutter™ for cleaning the pipe.

Always use CCTV camera while working.

Move the tool constantly back and forth while cleaning. Be especially careful when working in plastic pipes as the friction heat can melt the pipe .

Create Leaders for the most used Smart Cutters™ to enable quick tool changes and extend the service life of the flexible shaft.

Please read safety information on page 3 before assembly and use.

MAINTENANCE

CARING FOR THE FLEXIBLE SHAFT

The flexible shaft is pre-treated with **The Picote Flexible Shaft Lubricant (1350000020)** and the casing replaced prior to shipping. Always inspect the condition and apply lubricant between the flexible shaft and its outer casing when required. If necessary remove the shaft from its casing to treat. When the casing has been replaced, rotate manually for even coverage.



FASTENER SCREWS

If you are unable to tighten the fastener screws properly, due to worn out hex socket heads, replace the fastener screws immediately. Otherwise, a Smart Cutter™ can fall into the pipe while working.



DRILL HEAD BOLTS

Use Thread Sealant (Loctite 542 or similar) when tightening bolts which secure Front Metal Panel/Front Plastic Panel/Drill Head to the Hub. Otherwise, the front parts can fall into the pipe while working.

TRAINING

For information about product training and support contact Picote Solutions or your authorized Picote reseller.

PRACTICAL TIPS & SAFETY ADVICE

Here are some useful tips on how to get the most out of your Picote system. Always use the recommended tools for maintenance to avoid personal injury.



CUTTING THE FLEXIBLE SHAFT



Always inspect the flexible shaft before each use. If there are potential weak points or the shaft is damaged, cut off the damaged length using a band saw.



SHAFT ROUNDER



The shaft rounder smooths the end of the flexible shaft, preventing the user from being cut by the otherwise sharp metal edge.



ATTACHING A SHAFT SOCKET



Feed the shaft through the socket to the end and **securely fasten**. The outer casing should reach all the way to the base of the shaft socket to protect the shaft.

ADDING A VISUAL MARKER FOR SAFETY



Attach a visual marker (tape) to the outer casing of the flexible shaft. Place it around half a metre from the end point of the shaft. The mark will indicate the chain's location and prevent possible injuries when the Pipe Cutter is removed from the pipe, including injury by rotating parts.



CREATING LEADERS

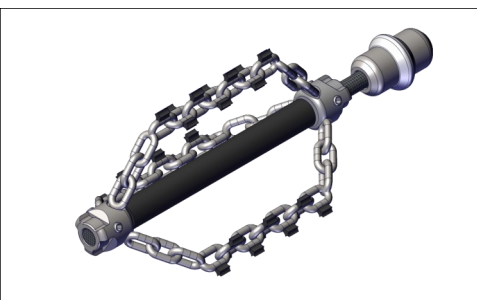

You can extend the life of the flexible shaft and increase productivity on site by making individual leaders for the most commonly used tools. This way you easily and quickly switch between tooling.

WARRANTY POLICY AND PROCEDURE

Limited Warranty:

Picote warrants to the original End User that the Product purchased by such End User will operate in accordance with and substantially conform to their published specifications when shipped or otherwise delivered to the End User and for a period of one (1) year, except electric motors for which the warranty period shall be six (6) months, provided, however, that Picote does not warrant any claim or damage under this

Warranty if such claim or damage results from:

1. Consumable parts or normal wear and tear resulting from use of the Products,
2. Product overload or overheated motor,
3. Regular periodic maintenance of Products,
4. Misuse, neglect, or improper installation or maintenance of the Products, or use of Products not for their intended purpose,
5. Products that have been altered, modified, repaired, opened or tampered with by anyone other than Picote or an authorized Picote Service Centre, or unsuitable or unauthorized spare parts, accessories or third party products when using the Products or;
6. the use of the Products not in compliance with their respective Documentation, user manuals, safety and maintenance instructions, and any usage restrictions contained therein, or
7. accident, fire, power failure, power surge, or other hazard.

Otherwise, the Products are sold AS IS. End User is responsible for using the Products within their specifications and instructions as contained in the Documentation.

EXCEPT AS SPECIFIED IN THIS WARRANTY, ALL EXPRESS OR IMPLIED CONDITIONS, REPRESENTATIONS, AND WARRANTIES INCLUDING, WITHOUT LIMITATION, ANY IMPLIED WARRANTY OR CONDITION OF MERCHANTABILITY, FITNESS FOR A PARTICULAR PURPOSE, NONINFRINGEMENT, SATISFACTORY QUALITY OR ARISING FROM A COURSE OF DEALING, LAW, USAGE, OR TRADE PRACTICE, ARE HEREBY EXCLUDED TO THE EXTENT ALLOWED BY APPLICABLE LAW. TO THE EXTENT AN IMPLIED WARRANTY CANNOT BE EXCLUDED, SUCH WARRANTY IS LIMITED IN DURATION TO THE WARRANTY PERIOD. BECAUSE SOME STATES OR JURISDICTIONS DO NOT ALLOW LIMITATIONS ON HOW LONG AN IMPLIED WARRANTY LASTS, THE ABOVE LIMITATION MAY NOT APPLY. This disclaimer and exclusion shall apply even if the express warranty set forth above fails of its essential purpose.

Please Contact:

Your Reseller or Picote

www.picotegroup.com



International Offices

Finland. United Kingdom. USA.

Technical Support

support@picotesolutions.com

Claims

claims@picotesolutions.com

Production & R&D

Pienteollisuustie 24

06450 Porvoo, Finland

support@picotesolutions.com

Authorized Resellers:

www.picotegroup.com/resellers